

Optimization Processes in Machinery Design: Combining Advanced Technologies and Mathematical Principles

Hadi Rahmazadeh Bahram^{1,*}, Hossein Navid¹, Shamsollah Abdollahpour¹, Razi Esmaeilpour Dizaji²

¹Department of Biosystems Engineering, University of Tabriz, Iran

²R&D Manager, Mashin Ara Shabnam Company, Iran

Received January 24, 2025; Revised April 24, 2025; Accepted May 18, 2025

Cite This Paper in the Following Citation Styles

(a): [1] Hadi Rahmazadeh Bahram, Hossein Navid, Shamsollah Abdollahpour, Razi Esmaeilpour Dizaji , "Optimization Processes in Machinery Design: Combining Advanced Technologies and Mathematical Principles," *Universal Journal of Mechanical Engineering*, Vol. 13, No. 1, pp. 1 - 11, 2025. DOI: 10.13189/ujme.2025.130101.

(b): Hadi Rahmazadeh Bahram, Hossein Navid, Shamsollah Abdollahpour, Razi Esmaeilpour Dizaji (2025). *Optimization Processes in Machinery Design: Combining Advanced Technologies and Mathematical Principles*. *Universal Journal of Mechanical Engineering*, 13(1), 1 - 11. DOI: 10.13189/ujme.2025.130101.

Copyright©2025 by authors, all rights reserved. Authors agree that this article remains permanently open access under the terms of the Creative Commons Attribution License 4.0 International License

Abstract Recent advancements in design methodologies and tools have significantly enhanced the optimization and innovation processes in machinery design. Engineers continuously refine machine mechanisms, focusing on specific functionalities through detailed case studies of individual components. This research introduces a novel optimization process that integrates the collaborative efforts of researchers and inventors, culminating in a fully optimized product. Rooted in permutation theory and mathematical principles, this approach utilizes simple mathematical methods as a foundation for developing advanced techniques to tackle the complexities present in modern industrial design processes. By systematically evaluating all potential configurations of machine mechanisms and performing virtual simulations, the most suitable designs can be selected based on defined criteria and local resource availability. This methodology not only fosters the development of high-quality machinery but also emphasizes energy efficiency and sustainability—critical aspects in contemporary design strategies aimed at meeting sustainable development goals, particularly in the agricultural machinery sector. Furthermore, the practical applicability and feasibility of this approach are demonstrated through a detailed case study, underscoring its relevance to the ongoing discourse on innovative design methods.

Keywords Design Optimization, Sustainable Design, Energy Efficiency, Machine Mechanisms, Innovative Design Methods

1. Introduction

The design of a machine is specifically tailored to perform a defined process addressing particular tasks related to external phenomena. The stages involved in machine design, as outlined by Lingaiah and Iyengar [1], include the following:

In addition to the fundamental elements of any manufacturing machine, several common steps should be followed as part of the design requirements. The Machine Design Handbook by Lingaiah and Iyengar [1] enumerates critical guidelines (not necessarily in order of application):

Design Elements: All elements must be considered, including machine geometry, applied forces, materials, etc.

Number of Machines Being Built: The design often depends on the production scale—specifically, how many machines are in production.

Lessons Learned: Insights gained from past experiences and mistakes play a significant role in guiding the design process.

Moreover, factors such as budget constraints, potential

mechanisms, transmitted forces, material selection, allowable stress, customer communication, high output and efficiency, durability, optimized design, maintenance, reliability, safety, ergonomics, and exceptional performance are also emphasized by Lingaiah and Iyengar [1].

These methodologies are further elaborated upon in Philip Kosky's book, "Exploring Engineering," which is recommended as a study resource for novice engineers [2].

Thus, various researchers present common methods for designing engineering mechanisms, which involve static and dynamic analyses alongside kinematic considerations. For instance, Lin [3] conducted a kinematic analysis of the oscillation of variable ratio face gear drives. Stress analysis is demonstrated by Kamandar et al. [4], addressing shear stress in impact harvesters, and Chatterjee focusing on vibration analysis in wind turbines [5]. In addition, stress analysis was carried out by Xiang [6], thermal analysis by Xiang [6] and Soleimania [7] and an examination of analysis and optimization in internal combustion engines was presented by Ding, et al [8]. Furthermore, process optimization through mathematical models has been explored by Dawid [9], Wang [10], while nonlinear mathematical models were discussed by Jing [11] and additional studies were highlighted in Hu, et al's research[12].

In the design process, utilizing software for analyses proves critical due to its significant advantages, as detailed in the Finite Element Method Handbook [13]. Notably, results obtained from precise calculations or finite element methods are readily reproducible in later design stages, while intuition-based decisions may be challenging for colleagues to validate.

Such analyses have wide-ranging applications in mechanical engineering, including fluid mechanics, where they help predict life cycles and failure factors, exemplified by Askari, et al [14]. All of these analyses contribute to modifications in production processes, as seen in the work of Moghaddam, et al [15], who utilized neural networks for maintenance process improvements in paper production. Similar proposals for new production processes, such as the aluminum elbow pipe production by Tao, et al [16], employed simulation and numerical analysis. Supplementary discussions provided by Jaber [17] elaborate on these issues in greater detail.

The analyses and optimizations mentioned serve as examples that showcase specialized methodologies, which continuously evolve with technological advancements. Ultimately, most research findings related to machine processes culminate in optimization recommendations that contribute to enhanced engineering designs. Each component of a machine evolves over time, and throughout this evolutionary process, various enhancements can be applied, resulting in significantly improved methodologies or principles. The final machine is constructed by integrating multiple mechanisms.

The complete design process typically involves a multidisciplinary team with a broad vision. Such machines may vary from simple mechanisms to complex systems relying on the integration of various intricate mechanisms to execute defined tasks. In this context, work diagram theory illustrates the material flow within the machine and the sequential operations that must be performed [18].

Various independent mechanisms, when combined, facilitate processes necessary for machine functionality. The assembly of these mechanisms leads to the creation of a machine, where components may undergo optimization by designers or be governed by advanced control tools. It is uncommon for a device to exhibit performance drastically different from its predecessors; as the saying goes, "There is no need to reinvent the wheel."

Different researchers and manufacturers propose various methodologies tailored to specific requirements in machine design. Initially, it is critical to identify and understand two categories of available machines: fully automated and semi-automated systems. Some organizations require entirely manual machines, while others may opt for semi-automated or fully automated solutions. Manufacturing plants commonly employ a combination of manual, semi-automated, and fully automated machines [19].

Significant advancements have been made in the design of semi-automated machines. For instance, grain harvesting combines and semi-automated robots for greenhouse product harvesting have been developed, including those by Satyam [20]. Additionally, fully automated devices, often referred to as intelligent robots, have been introduced for various applications, such as service robots designed by Makvandi, et al [21] and those for broccoli harvesting by Antonio [22]. Extensive research employing deep learning techniques has been undertaken, notable work by Kakade [23].

The utilization of powerful design software like SolidWorks and CATIA is indispensable, followed by evaluation and analysis using ANSYS and MATLAB Simulink. For example, Salimi's study [24], which focused on robot design for periodic inspection of power grid infrastructure, exemplifies this methodology.

In conclusion, diverse mechanisms and processes undergo optimization or evolution through the collective efforts of scientists and institutions to achieve varied objectives. It is crucial to recognize that innovative results in machine design and processes can arise from systematic methods that encompass comprehensive analyses and the integration of advanced technologies. These advancements not only improve the performance and efficiency of machines but also contribute to the ongoing development of engineering practices across various fields.

2. Materials and methods

In this article, we want to present a method that

incorporates the principles of mathematical counting, which is a new and complementary technique for work graph theory. Therefore, considering that each of these mechanisms is considered an independent variable, and a machine that consists of several groups of mechanisms is analyzed, we will have several groups of independent variables. Together, we will review the principle of multiplication [25].

The Multiplication Principle (MP): Assume that an event E can be decomposed into r ordered events E₁, E₂, ..., E_n and that there are:

- n₁ ways for the event E₁ to occur,
- n₂ ways for the event E₂ to occur,
- ⋮
- n_r ways for the event E_r to occur.

Then, the total number of ways for the event E to occur is given by:

$$n_1 \times n_2 \times \dots \times n_r = \prod_{i=1}^r n_i. \tag{1}$$

Example: To reach city D from city A, one has to pass through city B and then city C (see Fig. 1).



Figure 1. Diagram of different cities ways

If there are 2 ways to travel from A to B, 5 ways from B to C, and 3 ways from C to D, then by (MP), the number of ways from A to D via B and C is given by 2×5×3=30.

$$\left| \bigcup_{i=1}^k A_i \right| = |A_1 \cup A_2 \cup \dots \cup A_k| = \sum_{i=1}^k |A_i|. \tag{2}$$

An equivalent form of [MP] using set-theoretic terminology, is stated below.

Let

$$\prod_{i=1}^r A_i = A_1 \times A_2 \times \dots \times A_r = \{(a_1, a_2, \dots, a_r) \mid a_i \in A_i, i = 1, 2, \dots, r\} \tag{3}$$

Denote the Cartesian product of the finite sets, then;

$$\left| \prod_{i=1}^r A_i \right| = |A_1| \times |A_2| \times \dots \times |A_r| = \prod_{i=1}^r |A_i|. \tag{4}$$

And because we will use the concept of plural in the rest of the article, we will express it with an example.

The Addition Principle (AP): Assume that there are n₁ ways for the event E₁ to occur,

- n₂ ways for the event E₂ to occur,
- ⋮
- n_r ways for the event E_r to occur,

Where r ≥ 1. If these ways for the different events to occur are pairwise disjoint, then the number of ways for at least one of the events E₁, E₂, ..., E_r to occur is;

$$n_1 + n_2 + \dots + n_r = \sum_{i=1}^r n_i \tag{5}$$

Example 2. One can reach city Q from city P by sea, air and road. Suppose that there are 2 ways by sea, 3 ways by air and 2 ways by road (see Figure 2). Then by [AP], the total number of ways from P to Q by sea, air or road is 2 + 3 + 2 = 7.

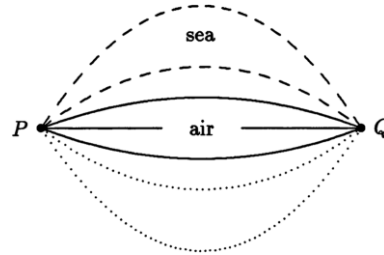

Figure 2. All paths between cities P and Q

An equivalent form of [AP], using set-theoretic terminology, is given below.

Let A₁, A₂, ..., A_r be any r finite sets, where r ≥ 1. If the given sets are pairwise disjoint, i.e., A_i ∩ A_j = ∅ for i, j = 1, 2, ..., r, i ≠ j, then

Different mechanisms designed for a part of the machine, regardless of the quality and accuracy of that work, are independent of each other and are considered independent variables. Therefore, in relation to other parts and more clearly; in connection with other mechanisms of a machine, its exact number can be obtained from the product of the number of existing mechanisms related to each part of the machine. As in the mentioned example, if a machine consists of two main parts and the number of mechanisms available to perform the work defined for them is 6 and 4 respectively, then this machine can be made in 24 permutations or in other words, 24 different ways.

In some cases, the two events that are supposed to form a machine are not compatible with each other, and if one happens, the possibility of the other is not possible, or both or one of them needs to be changed and adapted. In any case, the events that are incompatible should be removed from the above number.

This type of estimation can be generalized for complex machines consisting of several mechanisms. Therefore, the interesting result of this discussion reveals itself when a machine is made of more than two mechanisms. In the meantime, for a better understanding of the matter, we can consider a grain harvesting combine, which consists of parts such as the harvesting head, the material transfer part inside the combine, the threshing unit, the separation unit, the cleaning unit, the grain transfer unit, and the tank.

To apply the above method in complex machines, due to the incompatibility of some mechanisms with each other, several methods can be used.

The first method in which a machine is based on the process it performs, its beginning and end are determined continuously. In the case of the example, the harvester head is at the beginning of the machine and the transfer unit and tank are at the end of the machine. Two mechanisms are

examined in relation to each other, and the types of mechanisms designed for each are examined (by the number of n_a and n_b respectively). In the next step, based on the multiplication principle, the total number of combinations in which the two mechanisms can be placed together is obtained as follows ($s_1=n_a \times n_b$). By subtracting the incompatible mechanisms from each other, the value s_1' is obtained, which is a configuration with specific and distinct conditions [25].

In the second step, the total number of configurations that can occur for the second and third mechanisms is examined, and eventually s_2' is obtained. In this way, all configurations up to s_{n-1}' are calculated, and based on the addition principle, the total number of possible designs is calculated as $S=s_1'+s_2'+\dots+s_{n-1}'$.

The second method involves dividing a machine into two or a maximum of three main mechanisms; for example, for the combine, the machine can be divided into harvesting, separating grains from straw, and transferring. Each part is examined as an independent set using the previous method, and after adding, the values s_1' , s_2' , and s_3' are obtained in turn. Finally, using the multiplication principle, as with the general method mentioned at the beginning, the calculation is performed ($S=s_1' \times s_2' \times s_3'$). In dividing the machine into two or a maximum of three main parts, there may be more than three mechanisms in each group and one of the two methods above can be utilized for calculating the number of possible configurations for each group.

In examining the types of mechanisms designed for each machine, this part of the machine may be overlooked due to simplicity or limited number of mechanisms. Ultimately, after summarizing and making a decision, one of the compatible, economical, or suitable mechanisms with work conditions and manufacturing methods is selected.

After obtaining all possible configurations for the design

of a machine, the ultimate goal is to design a unique machine that has no resemblance or equivalent, and in terms of quality, it surpasses produced examples. Therefore, the total number of possible configurations (S) certainly includes previously designed configurations (D) that must be omitted ($M = S - D$). After the methodology of the number of machines that can be designed by combining mechanisms where no human has yet considered, interesting results arise. The final choice among several combinations of mechanisms that no engineer has yet attended to is made. The construction of a machine based on various conditions such as; production capability, accessible after-sales service for the customer, ease of machine for remote areas, starting from simple combinations and later, using more complex versions, marketability due to the use of a specific mechanism in a part of the machine, and other conditions determined by the management team of the machinery complex, are specified.

Additionally, one of the most comprehensive methods for feasibility studies is provided by Holger [26], and a design team can be trained and use it to finally decide and choose the best combination.

3. Case Study: Design of Feeder Mixer Machines for Industrial Farms

Considering that the choice of the power supply system is often customized based on local facilities and other factors, we will simplify our analysis by focusing on two additional columns. The information presented in Table 1 has been extracted from various sources of patents related to this issue (Google Patent) and is articulated in the following table (Table 2):

Table 1. Different parts of feeder mixer and its types

Row	Stirrer inside the tank	Ration distribution mechanism	power transmission
1	Cylindrical helix	Horizontal conveyer	PTO power transmission
2	A simple conical helix with a cylindrical axis	Inclined conveyer	AC Electric power
3	A simple conical helix with jagged edge and a cylindrical axis	sweeper	DC Electric power
4	A simple conical helix with a conical axis	Fixed rate sweeper	Engine powered
5	Helix with modified spiral	Variable rate sweeper	
6	Conical meshed helix with cylindrical axis	Transverse helix	
7	Longitudinal cylindrical helix	Independent propeller player	
8	Longitudinal rod stirrer	Centrifugal spreader on a helix	
9	No helix [conveyor chain]	Independent blade spreader	

Table 2. Various sources of patents for different mechanisms

Row	Agitator mechanism inside the tank	Schematic	Inventors or exploiters	Ration distribution mechanism	Schematic	Inventors or exploiters
1	Cylindrical helix		[27]; [28];	Horizontal conveyor		[29]; [30]; [31]; [32]; [33];
2	A simple conical helix with a cylindrical axis		[34]; [35];	Inclined conveyor		[36];
3	A simple conical helix with jagged edge and a cylindrical axis		[31]; [37]; [38]; [39]; [32]; [40]; [41];	sweeper		[42]; [43]; [35]; [44]; [45]; [31];

Table 1 continued

<p>4</p>	<p>A simple conical helix with a conical axis</p>		<p>[46]; [47]; [36];</p>	<p>Fixed rate sweeper</p>		<p>[27]; [34]; [35]; [38]; [48]; [49]; [32][40]; [41];</p>
<p>5</p>	<p>Helix with modified spiral</p>		<p>[45]; [44]; [32];</p>	<p>Variable rate sweeper</p>		<p>[44]</p>
<p>6</p>	<p>Conical meshed helix with cylindrical axis</p>		<p>[47];</p>	<p>Transverse helix</p>		<p>[31]; [50]; [51]; [52];</p>

Table 1 continued

<p>7</p>	<p>Longitudinal cylindrical helix</p>		<p>[51]</p>	<p>Independent propeller player</p>		<p>[37]</p>
<p>8</p>	<p>Longitudinal rod stirrer</p>		<p>[29]</p>	<p>Centrifugal spreader on a helix</p>		<p>[53]; [35];</p>
<p>9</p>	<p>No helix [conveyor chain]</p>		<p>[30]; [33]; [52];</p>	<p>Independent blade spreader</p>		<p>[35]</p>

Table 2 is a summary of many existing resources that have been registered by different inventors, illustrating efforts to optimize current systems and add precise control to these machines. This table aims to categorize and explain the mechanisms based on the subject matter and available information.

It should be noted that the names of each mechanism are designated according to the type and working method of that mechanism; however, researchers or inventors may not have consistently used these specific terms.

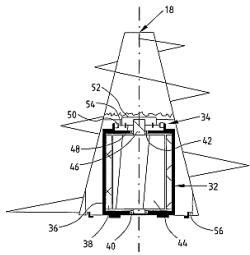
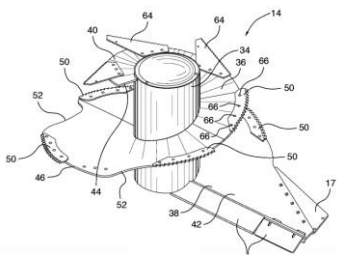
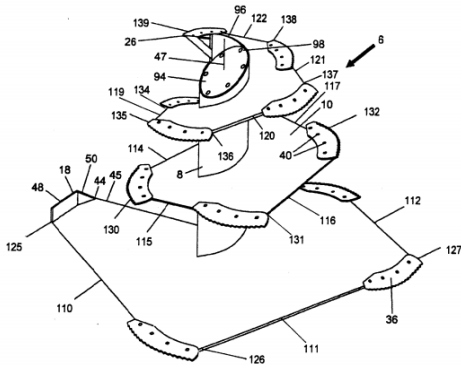
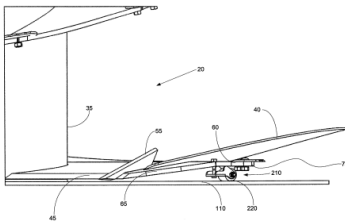
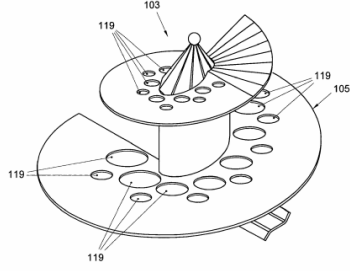
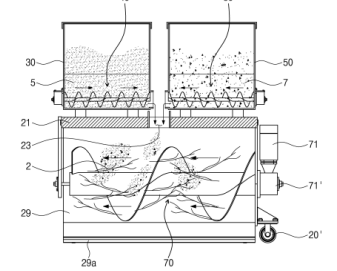
The following table clearly expresses the combination of the stirring mechanism inside the tank (horizontal) and the ration distribution mechanism (vertical) for the existing systems, marked with the (✓) symbol. Empty areas indicate that such a combination of the two systems has not yet been developed. Areas marked with the (Φ) symbol indicate that these combinations are incompatible due to their operational nature and cannot coexist.

Following the summarization in Table 2, we now turn to Table 3, which outlines additional characteristics of the various mechanisms employed in feeder mixers. This table will provide further insights into the advantages and disadvantages of each combination, helping manufacturers and researchers evaluate the most suitable options for their specific needs.

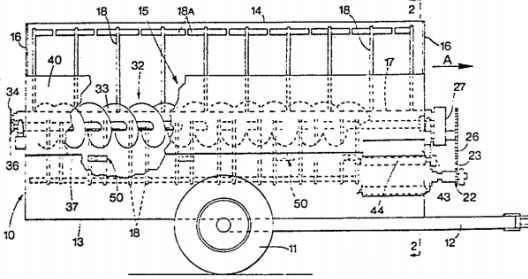
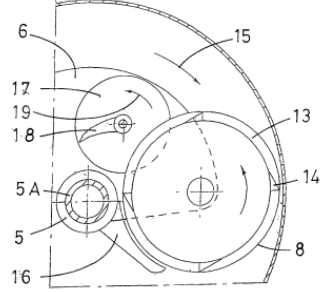
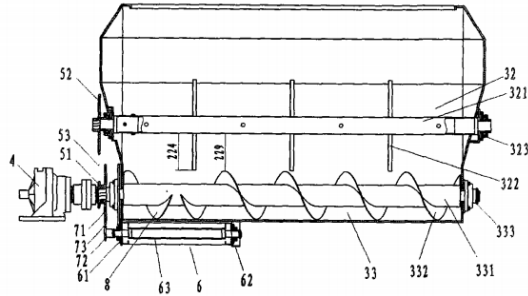
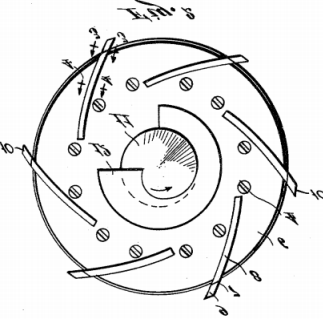
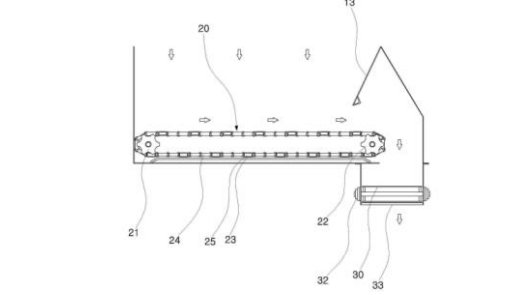
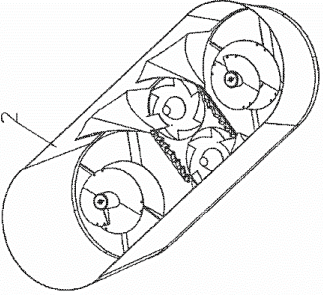
According to Table 3, which is the result of examining various sources, it is clear that out of the $9 \times 9 = 81$ potential combinations of mechanisms, only 24 combinations have been created so far. Additionally, there are 14 combinations that cannot be combined with each other due to the operational nature of each component. In other words, these combinations are incompatible.

Thus, the number of combinations where no action has been taken yet is equal to:

$$81 - (24 + 14) = 43$$

This calculation highlights that there remains significant room for innovation in these combinations. Moving forward, we aim to explore and identify viable combinations of two parts of the feeder mixer device, focusing on the most popular mechanisms derived from those most frequently repeated in Table 3. The goal is to provide a suitable summary of the 43 combinations and suggest them to designers interested in this field.

Sometimes, by combining two mechanisms or choosing one of them, each of which pursues a more complete goal, the circle of choice can be made smaller. Here, the selection circle is narrowed by the combination of the longitudinal rod stirrer and the longitudinal cylindrical helix, which is more popular than the separate form of each. Additionally, choosing one of the simple conical helices with multiple blades and a cylindrical or conical axis, which respectively serve the purposes of mixing and shredding, helps streamline the decision-making process.

By equipping the conical axis helix with jagged edges, the cutting operation can be performed with greater reliability and less wear and tear. Consequently, the selection and decision-making range for creating a new system has become smaller. From now on, the selection range will increase from 43 to 10 combinations (Table 4), making decisions easier and more aligned with preferences or based on existing conditions such as workshop facilities, the popularity of certain types of mechanisms in a region, the type of drive system available, economic efficiency, etc.

Table 3. Combination of the stirring mechanism inside the tank [horizontal] and the ration distribution mechanism [vertical]

Agitator mechanism inside the tank	Cylindrical helix	A simple conical helix with a cylindrical axis	A simple conical helix with a conical axis	A simple conical helix with jagged edge and a cylindrical axis	Helix with modified spiral	Conical meshed helix with cylindrical axis	Longitudinal cylindrical helix	Longitudinal rod stirrer	No helix [conveyor chain]
Ration distribution mechanism									
Horizontal conveyor		√	√	√			√	φ	√
Inclined conveyor			√						
sweeper		√		√	√		φ	φ	φ
Fixed rate sweeper	√	√	√	√	√		φ	φ	φ
Variable rate sweeper				√			φ	φ	φ
Transverse helix				√			√		√
Independent propeller player		√				√			
Centrifugal spreader on a helix	√	√	√			φ	φ	φ	φ
Independent blade spreader				√					

Table 4. Decision to choose the right combination

Agitator mechanism inside the tank	A simple conical helix with a cylindrical axis	A simple conical helix with jagged edge and a cylindrical or conical axis	Helix with modified helix	Combination of rod stirrer and longitudinal cylindrical helix
Ration distribution mechanism				
Horizontal conveyor	√	√		√
Fixed rate sweeper	√	√	√	φ
Horizontal conveyor		√		√
Independent propeller player	√			
Independent blade spreader		√		

4. Conclusions

In this study, we examined the mechanisms involved in the optimization of manufacturing processes and identified several key factors that contribute to increased efficiency and output. Our findings suggest that the integration of advanced technologies and systematic analysis can significantly enhance productivity in this sector. However, it is important to acknowledge that our research faced limitations, including a limited sample size and the scope of machinery analyzed, which may affect the generalizability of the results.

We recommend that future research explore the application of emerging technologies, such as AI and machine learning, in various manufacturing environments to further validate our findings. Ultimately, our study emphasizes the importance of continuous innovation and adaptation in engineering design processes, underscoring the need for ongoing research to address the evolving challenges in the industry.

REFERENCES

- [1] Lingaiah, K and Narayana Iyengar B. R. *Machine Design Data Handbook, Metric Units*. Bangalore. s.l.: Suma, 1973.
- [2] Kosky, Philip; Robert Balmer; William Keat; George Wise, "Exploring Engineering [An Introduction to Engineering and Design]", s.l, Academic Press, 978-0-12-415891-7, 2013.
- [3] Lin, C; Gong H; Nie N; Zen Q; Zhang L, "Geometry design, three-dimensional modeling and kinematic analysis of orthogonal fluctuating gear ratio face gear drive", *Proceedings of the Institution of Mechanical Engineers, Part C*, *Journal of Mechanical Engineering Science*, Vol. 227, no. 4, pp. 779-793, 2013.
- [4] Kamandar, Mohammad Reza, Jafar Massah and Majid Khanali, "Quasi-static and impact cutting behavior definition of privet stem", *gricEngInt:CIGR Journal*, Vol. 20, 2018.
- [5] Chatterjee, P and Bryant, M, "Analysis of tension-tunable clamped-clamped piezoelectric beams for harvesting energy from wind and vibration", *Journal of Intelligent Material Systems and Structures*, Vol. 30, no. 16, pp. 2405-2420, 2019.
- [6] Xiang, Q and Yin, Zn, "Investigation of temperature effect on stress of flexspline", *Appl.Math. Mech.-Engl. Ed*, Vol. 35, pp. 791-798, 2014.
- [7] Soleimania, Ali, Pedram Hanafizadeha and Amirmohammad Sattaria, "Subcooled two-phase flow boiling in a microchannel heat sink: comparison of conventional numerical models", *Journal of Computational Applied Mechanics*, Vol. 51, June 2020.
- [8] Ding, Zemin, Lingen Chen and Fengrui Sun, "Finite time exergoeconomic performance for six endoreversible heat engine cycles", *Applied Mathematical Modelling*, pp. 728-736, Unified description, 2011.
- [9] Dawid, Liu, Z, Lv and B, Li, *Mathematical model and geometrical design method of noncircular face gear with intersecting axes*. *Proceedings of the Institution of Mechanical Engineers, Part C, Journal of Mechanical Engineering Science*, Vol. 235, no. 21, pp. 5902-5914, 2021.
- [10] Wang, D, "Nonlinear dynamics of asymmetrically supported supercritical rotor equipped with a dry friction damper", *Proceedings of the Institution of Mechanical Engineers, Part C: Journal of Mechanical Engineering Science*, 2022.
- [11] Jing, X, "The X-structure/mechanism approach to beneficial nonlinear design in engineering" *Appl. Math. Mech.-Engl. Ed*, Vol. 43, pp. 979-1000, 2022.
- [12] Hu, W and Tsun-kuei, W, "A Donnell type theory for finite deflection of stiffened thin conical shells composed of composite materials", *Appl Math Mech*, pp. 857-868, 1990.
- [13] Zienkiewicz, O. C, Robert L. Taylor and J. Z. Zhu, "The Finite Element Method: Its Basis and Fundamentals", Oxford: Elsevier Butterworth-Heinemann, 2005.
- [14] Askari, Amir and Ali Falavand Jozae, "Numerical simulation of the effect of particle size on the erosion damage in ball valves of pressure reducing station", *Journal of Computational Applied Mechanics*, Vol. 52, no. 1, 2021.
- [15] Moghaddam, Masoud Azadi and Farhad Kolahan, "An empirical study on statistical analysis and optimization of EDM process parameters for inconel 718 super alloy using D-optimal approach and genetic algorithm", *Journal of Computational Applied Mechanics*, Vol. 46, pp. 267-277, 2015.
- [16] Tao, R, Xu, X and Fan, Y. "Differential flow velocities control method for pushbending of the thin-walled tube with a 0.9D bending radius by differential lubrication", *Int J Adv Manuf Technol*, 2022.
- [17] Jaber, M.Y., J. Peltokorpi and T.L. Smunt, "The lot size problem and the learning curve: A review of mathematical modeling (1950's -2020)", *Applied Mathematical Modelling*, Vol. 105, pp. 832-859, 2022.
- [18] Ajit K., Srivastava, Carroll E. Goering and Roger P. RohrbachDennis R. Buckmaster, "Engineering Principles of Agricultural Machines", *American Society of Agricultural and Biological Engineers MI 49085-9659*, p. 6. ASAE Publication 801M0206. 1-892769-50-6, 2006.
- [19] CAD/CAM/CAE, The Essentials of. www.machinedesign.com [Online] Nov 09, 2013.
- [20] Raikwar, Satyam, Jens Fehrmann and Thomas Herlitzius, "Navigation and control development for a four-wheel-steered mobile orchard robot using model-based design", *Computers and Electronics in Agriculture*, Vol. 202, p. 107410, 2022.
- [21] Makvandi, Alireza and Hesam Makvandi, "Routing and avoiding collisions of autonomous robots in unknown environments with fixed and moving obstacles", *Journal of Computational Applied Mechanics*, Vol. 53, no. 2, pp. 169-182, 2020.
- [22] Garc á-Manso, Antonio, "Towards selective and automatic harvesting of broccoli for agri-food industry", *Computers*

and Electronics in Agriculture, Vol. 188, 2021.

- [23] Kakade, A.V, "Object Detection in Satellite Images Using Modified Pyramid Scene Parsing Networks", In Sensor Data Analysis and Management [eds A. Suresh, R. Udendhran and M.S. IrfanAhmed], 2021.
- [24] Salimi, Mohammad Hosein and Majid Roshanfar, "Design and implementation of an unmanned aerial vehicle for inspection of electricity distribution networks", Journal of Computational Applied Mechanics, Vol. 47, 2016.
- [25] Chuan-Chong, Chen and Koh Khee, "Meng principles and Techniques in Combinatorics", NUS, Singapore. p. 1. 9789810211394, 9810211392, July 1992.
- [26] Schumann, Holger, "A Method for Feasibility Studies of New System", Procedia Computer Science, Vol. 44, pp. 578-587, 2015.
- [27] William, S and Knight, "AUGER WITH FORWARD ANGLED LEADING EDGE", US 6,863,433 B2 United StatesAssignee: Kuhn Knight Inc, 2005.
- [28] Pellman, David C, "MIXING SCREW", US 9,724,656 B2 United States, Assignee Patz Corporation, Aug 8, 2017.
- [29] linger, Brarry anthony, "mixing and dispensing machine for animal feed", United Kingdom Patent Application GB2076678A, Current Assignee Howard Machinery Ltd. Date: 1981.
- [30] Lee, Hannah, "Electric Feeder" Korean Registration number 10-0971383, Korean Intellectual Property Office [KR], 2010.
- [31] Huberdeau, Joel Joseph and Jack Hendriks, "Auger for Feed Mixer", US 2008/0101154 A1 United States, May 01, 2008.
- [32] Baker, John and Sarnia, "VERTICAL FEED MIXER HAVING CUTOOUT EDGE", *United States Patent*, US 8,540,177 B2 Assignee: Penta TMR Inc, Petrolia [CA], Sep 24, 2013.
- [33] Oh, Heonshik, Yeonsu Yoo and Joonghae Choi, "TMR and Concentrated fodder Mixture Feeder that can supply Customized Feeds According to the Cow Growth Stage", KR20220012553A South Korea, 08 19, 2022.
- [34] Baker, John and Samia, "VERTICAL FEED MIXER", *United States Patent*, US 2010.0039885A1 United States, Feb 18, 2010.
- [35] Liet, Cornelis Hendricus and Losser. CONVEYOR DEVICE. US 2013/0058.189 A1 United States Patent Application, march 7, 2013. Assignee: TRIOLIET HOLDING B.V., Oldenzaal, And Pub.
- [36] Hansen, Henrik Lund, "PIVOTABLE FEED MIXER", US010609897B2 United States, Apr 7, 2020.
- [37] Cornelis Hendricus Liet, PJ Losser [NL], "FOOD MIXER", United States Patent, Assignee; Trioliet Mullos B.V., BE Oldenzaal [NL], Publication number US 2009/027734.0 A1, Publication date Nov. 12, 2009.
- [38] Reggie, L, et al, "VERTICAL FEED MDXER WITH FEED OEFLECTORS", USOO560362A United States, Feb 11, 1997.
- [39] Kooima, John C. and Philip G. Kooima, "AGRICULTURAL FEED MIXER BLADE", USOO5823449A United States, Oct 20, 1998.
- [40] Charles Cavanagh, Dermot Gallagher; "An auger", Patent, Publication number; S2005/0349, Publication date 27.05.2005.
- [41] TAMMING, Jakob, Gavin MILLS and Christopher BESSEY, "AUGER WITH CONTINUOUS KNIFE", US 2014/0374522 A1 United State, Jay Lor International Inc Dec 25, 2014.
- [42] Tamminga, Jakob, "Vertical feed mixer with auger having center post with sloped top", US 6,328,465 B1 United States, 10 08, Jay Lor International Inc, 2000.
- [43] Liet, Cornelis Hendricus and PJ Losser, "FOOD MIXER" US 2009/027734.0 A1 US, Assignee: TRIOLIET HOLDING B.V., Oldenzaal, Nov 12, 2009.
- [44] Tamminga, Jakob, "Auger for vertical mixer", US20100108794A1 United States, 05 06, Assignee: Jay Lor International Inc, 2010.
- [45] Jacob, R and Tamminga, Orton, "VERTICAL FEED MIXER WITH AUGER HAVING CENTER POST WITH SLOPED TOP", US 6,328,465 B1 United States, Assignee: Jay-Lor Fabricating Inc, Dec 11, 2001.
- [46] Hahn, Klaus, "feed mixer", DE 103 45 322 A1 Deutsche, 05 04, Patent- und Markenamt, 2005.
- [47] Boekhorst, Te, Paulus Andreas Johannes and SJ Lettele, "Auger and animal fodder mixing and dispensing apparatus including such an auger", EP 1 864 571 A1 EUROPEAN, Applicant: Schuitemaker Machines B.V.NL-7461 AG Rijssen [NL], 2007.
- [48] Christopher Albright, Brodhead, WI [US]; Tim Osterhaus, Stoughton, WI [US]; "MIXER WITH DISSIMILAR AUGERS", Google patent Assignee: Kuhn Knight Inc., Brodhead, WI [US], Publication number US 6,905,238 B2, Publication date Jun. 14, 2005.
- [49] Plas, Nicolaas Van Der and Oldenzaal, "MIXER", US 20040252583A1 United States, Dec 16, 2004.
- [50] Seo, Jeongil, "Movable apparatus for aligning feedstuf". KR20200078123A South Korea, 07 01, 2020.
- [51] Newswanger, Leon R, "PORTABLE COMBINATION HORIZONTAL GRINDERMIXER", US 2011/0180642 A1 United States, Jul 28, 2011.
- [52] Young-kiKim, Hong, Sang-cheolKim and Guk-hwan, "feeding apparatus and operation method using the same, feeding system for domestic animal". KR20180051985A South Korea, 05 17, 2018.
- [53] Lowry, Warren M. and Williamstown. "CIRCULATING AND DESINTEGRATING ROTOR FOR PULPNG APPARATUS", 3,171,606 United States, Assignee: Jones Corporation, Pittsfield, Mass., a corporation of Delaware, 1962.