

Wavelet-PCA Based Denoising of Partial Discharge Signals

Ephraim T. Iorkyase

Department of Electrical and Electronics Engineering, Joseph Sarwuan Tarkaa University, Nigeria

Received July 6, 2023; Revised August 21, 2023; Accepted September 22, 2023

Cite This Paper in the Following Citation Styles

(a): [1] Ephraim T. Iorkyase , "Wavelet-PCA Based Denoising of Partial Discharge Signals , "Universal Journal of Electrical and Electronic Engineering, Vol. 10, No. 3, pp. 43 - 50, 2023. DOI: 10.13189/ujeee.2023.100301.

(b): Ephraim T. Iorkyase (2023). Wavelet-PCA Based Denoising of Partial Discharge Signals. Universal Journal of Electrical and Electronic Engineering, 10(3), 43 - 50. DOI: 10.13189/ujeee.2023.100301.

Copyright©2023 by authors, all rights reserved. Authors agree that this article remains permanently open access under the terms of the Creative Commons Attribution License 4.0 International License

Abstract Partial Discharge measurements contain valuable information about the state of the insulation system that is useful for the diagnosis of electrical equipment. Signals that result from on-site PD measurement are often completely buried in noise. One critical task for PD analysis and diagnosis is the recovery of clean PD signals from heavily contaminated measurements. Removing noise from PD measurement remains a serious challenge because the majority of the noise encountered during on-site measurement has similar time and frequency characteristics to the desired PD signals. This paper presents a sophisticated technique for denoising PD measurement. More specifically, we propose to combine Wavelet Transform (WT) and Principal Component Analysis (PCA) to recover PD signals buried in excessive noise. The first phase is based on multi-resolution signal decomposition via wavelet. In the second phase, the coefficients that result from signal decomposition are filtered using PCA to retain the most informative signal characteristics of the measured PD signal. PCA automatically discards the uncorrelated noise that remains in the wavelet coefficients. An assessment of the proposed denoising technique is carried out, by processing experimental PD data. The results indicate that the proposed technique not only suppresses all kinds of noise present but also effectively preserves the features of the PD signals.

Keywords Noise, Partial Discharge, Principal Component Analysis, Wavelet Transform

1. Introduction

Partial Discharge (PD) monitoring has become a dominant tool for assessing the condition of insulation in electrical equipment. According to the International Electro-technical Commission (IEC) 60270 standard on high voltage test technique - partial discharge measurement, PD is defined as a localized electrical discharge that only partially bridges the insulation between conductors which may or may not occur adjacent to a conductor [1]. Investigations have shown that PD precedes insulation failure, and it can be a very clear indicator of plant failure. This has fostered growing interest in developing efficient and practical PD condition monitoring systems for electrical equipment with the capacity for early detection of PD before it grows into complete breakdown and/or causes unexpected power failure. PD measurement can be done entirely on-site and/or on-line without de-energizing any equipment. The major problem encountered with such measurements is the presence of noise and interference. Electrical substation where PD is expected is usually characterized by noise and interference. Electromagnetic emissions are the primary sources of interference in electrical substations. Neighbouring communications systems (broadcast, GSM, etc.) and systems that operate in the same frequency band can also be sources of interference. PD measurement can be influenced by the presence of both broadband and narrowband interference. Broadband signals are signals with bandwidth significantly greater than the channel coherence bandwidth. They are often generated by switching operations (making and breaking of current paths), lightning discharges, partial discharges and

corona which produce pulsed RF signals with short pulse duration and low repetition rate [2]. Narrowband signals are said to occupy a bandwidth that is less than the channel coherence bandwidth. Such signals are generated by logic circuits and wireless broadcast systems (AM and FM radio, analogue terrestrial TV etc.) [2]. Although switching actions produced by switchgear are needed to protect equipment against faults and to control energy flow [3], they are a major cause of high frequency electromagnetic interference propagated in the bus bars with typically fast rise-times. The bus bars act as antennae that radiate the electromagnetic field into the environment [4]. The EMI that results from switching actions is dependent on the type of substation, circuit breakers and bus being excited [5]. Electrical discharge (partial or full) can be a troublesome source of interference. They can occur in any electrical insulation under voltage pressure. These discharges result from rapid ionization due to the electric field in the insulation generated by the applied voltage. The resulting pulse currents generate unwanted electromagnetic radiation, typically consisting of a train of short (nanosecond) impulses [6]. Corona discharge is a special form of partial discharge that occurs when the voltage gradient at the surface of a conductor is sufficiently high to cause ionization of the air surrounding it [7]. The electromagnetic interference originating from switching activities and partial discharge is non-Gaussian, impulsive and broadband in nature. Impulsive noise is much different from most of the interference sources for which typical wireless systems are designed. It has a short duration (between 100 and 500 ns), a large frequency band (from DC to several GHz), a high magnitude compared to other noises and is difficult to predict [8]. Such noisy measurements with low signal-to-noise ratio (SNR) present difficulty in PD analysis. And since we cannot eliminate all sources of interference in the environment, there arises a need for an effective method for denoising PD measurements before carrying out any analysis.

Several techniques have been developed for eliminating or suppressing noise in PD measurements. Their effectiveness depends on the type of noise or interference present in the measurement. Narrow-band interferences such as DSI, which have their energies concentrated around a dominant frequency, can be identified, and eliminated using frequency domain techniques such as Fourier transform [9]. Interference from switching operations can be eliminated in the time domain but with losses as PD occurring at the same time instant is also eliminated. Another limitation of these methods is that they require prior knowledge of the noise present and the characteristics of the reference signal, which can be extremely difficult, especially for on-site PD measurement. Wavelet techniques have also been used to remove noise from PD measurements [10] [11]. The principle of wavelet transform is based on signal decomposition through selected wavelet functions. By applying thresholds to the

decomposed signals and performing signal reconstruction, PD signals can be recovered from noisy measurements. However, frequency scales of stochastic noise can be the same as those of PD signals. This implies that it may be difficult to distinguish PD signals from stochastic noise using wavelet transform. There is, therefore, need for a more sophisticated technique that will not only eliminate all types of noises/interferences from PD measurement but can also preserve the characteristics of the PD signal as much as possible. This paper presents an investigation into the combination of the wavelet decomposition technique and the well-known Principal Component Analysis (PCA) [12] [13] for PD signal denoising. The Wavelet-PCA hybrid denoising technique harnesses the advantages of both techniques to establish an effective method for denoising PD measurements.

The rest of the paper is organized as follows: Section II describes the formulation of the PD denoising problem. The background theory of the proposed technique is captured in section III. Section IV presents the experimental procedure for acquiring PD measurements. Section V gives the performance analysis of the wavelet-PCA denoising method. Finally, a conclusion is drawn in section VI.

2. Problem Formulation

The problem of de-noising partial discharge signal can be modelled as in Equation 1.

$$P(n) = X(n) + e(n) \quad (1)$$

where P , is the noisy PD measurement that contains both the PD signal, X , and noise e . The aim is to recover the PD signal buried in noise by removing the noisy component of the measured signal. Wavelet technique which involves decomposition of measured data and thresholding is usually used for de-noising PD measured data. In this paper, a de-noising technique that combines Wavelet transform and PCA is used to de-noise the PD measurements buried in excessive noise without assuming any a priori knowledge about the PD features or the noise component.

3. Background Theory

3.1. Wavelet Transform

Partial discharge activities have been measured by making use of coupling sensors attached to electrical apparatus. But with advances in technology, various signal processing tools such as Fourier Transforms (FT), Short Time Fourier Transform (STFT) [14] and Wavelet Transform (WT) have been introduced for PD signal analysis. However, Fourier transformation comes with the loss of information in time, since only spectral information in the frequency domain is captured. To overcome the

problem associated with the Fourier transform, STFT was introduced. STFT represents the signal in both time and frequency domain using moving window function. The major drawback of STFT is that it does not give multi-resolution information of the signals because of the constant window size. To overcome the problems associated with Fourier transform based methods, wavelet transform was proposed. A wavelet is a wave-like oscillation, which has its energy localized in time. Wavelet transform is similar to Fourier analysis, but instead of decomposing a signal into sine and cosine waves, wavelet transform decomposes a signal into oscillations localized in space and time, thereby allowing efficient access to localized information about the signal. Wavelet transform is a mathematical tool for analyzing transients and non-stationary signals. The main advantage of wavelet transform is that it has a varying window size which is broad at low frequencies and narrow at high frequencies leading to an optimal time-frequency resolution in all frequency ranges. There are two main types of wavelet transforms: Continuous Wavelet Transform (CWT) [15] and Discrete Wavelet Transform (DWT) [16] [17]. The DWT, which is a modification of CWT, was developed to overcome the drawbacks inherent in CWT, redundancy, and computational complexity.

3.2. Discrete Wavelet Transform

A discrete wavelet transform is a transform for which the wavelets are discretely sampled. DWT captures both frequency and location information (location in time). It decomposes a signal into a number of sets, where each set is a time series of the wavelet coefficients; approximation and detail coefficients, describing the time evolution of the signal in the corresponding frequency band. This is accomplished by passing the time-domain signal through a cascaded system of low and high pass filters. Rather than take the scalar product of the scaling function or the wavelet with the signal, we convolve the signal with these filters. Figure 1 shows the filtering process, which demonstrates the discrete wavelet decomposition procedure. The filter outputs are the approximation and detail coefficients. The approximation coefficients represent the low frequency, high-scale information of the signal while the detail coefficients represent the high frequency, low-scale information in the signal. The approximation coefficients are further decomposed into another level of detail and approximation coefficients. This process continues until the final decomposition level. DWT reveals the localized characteristics of the measured PD signal.

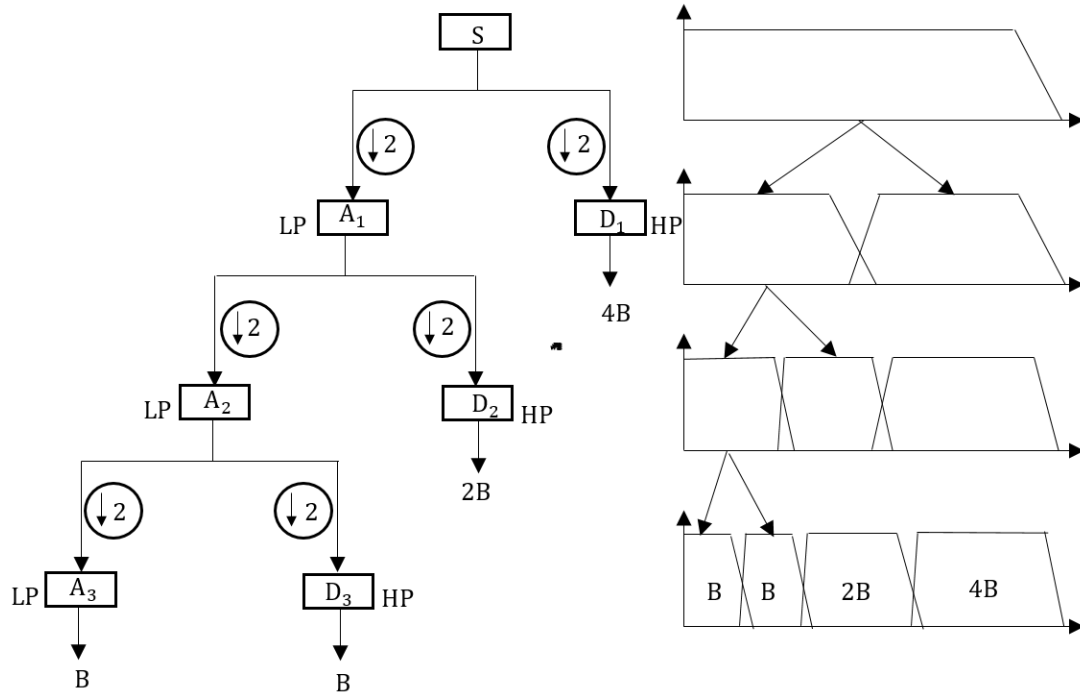

Figure 1. DWT filter decomposition

3.3. Principal Component Analysis

Principal component analysis is an unsupervised learning algorithm that is used to summarize the information content in a large dataset by means of a small set of indices or variables that can be easily visualized in order to observe trends. The important information extracted from the data can be expressed as a set of summary indices called principal components. Statistically, PCA is a de-correlation technique. The main goal is to reduce the dimensionality of a dataset while preserving the most important patterns or relationships between the variables without any prior knowledge of the target variables. PCA has been applied to data compression [18], image enhancement [19], and denoising [20]. Even though PCA methods vary significantly with application, they are similar in that they deconstruct a multi-channel signal into a set of orthogonal bases of decreasing energy. PCA transforms data into a set of orthogonal directions otherwise known as Principal Components (PC) such that the first axis is along the direction where the data has the greatest variance and so on [21] [22]. The first components with the most energy tend to capture the coherent data signal whereas the later components with less energy tend to represent the incoherent noise in the data. The matrix that transforms the data is defined by decomposing the covariance matrix C of the data into its corresponding eigenvalues and eigenvectors as in Equation 2.

$$C = VQV^T \quad (2)$$

Where the diagonal matrix Q consists of the eigenvalues of C and the eigenvector matrix V contains the eigenvectors (column of V). The direction of the principal components is defined by the eigenvectors. The rotation matrix V^T decomposes the signal. In compact notation, this decomposition is given in Equation 3.

$$\phi = V^T P \quad (3)$$

And the PD signal can be reconstructed by Equation 4.

$$\hat{P} = V\phi \quad (4)$$

The reconstruction is said to be exact and unique. This is because V is a unitary matrix and satisfies $VV^T = I$, where I is an identity matrix. Theoretically, the signal that is reconstructed from all the PCs is the same as the original measured PD signal. However, PCA is expected to reduce the dimension of the original signal. Therefore, only a subset of the most informative PCs is used to reconstruct the signal after decomposition. This yields a truncated version of the original signal without the discarded PCs. In the context of de-noising, discarding incoherent noisy

components before reconstruction will produce a clean version of the signal with an acceptable level of distortion. Mathematically, this is given by Equation 5.

$$X = VBV^T P \quad (5)$$

where B is a diagonal matrix, with ones at the rows corresponding to the components used for reconstruction, and zeros elsewhere.

4. PD Measurement

An experiment was conducted to simulate the measurement of partial discharge activities. The laboratory used for the experiment is in the building that housed the Department of Electronic and Electrical Engineering at the University of Strathclyde. The laboratory contains different metallic objects. The surrounding environment is characterized by communication systems and background noise. The presence of clutter and communication systems in this laboratory makes its radio environment sufficiently noisy to generate the noise-contaminated PD measurement that will enable evaluation of the signal denoising techniques being investigated. The simulated PD source comprises a pulse generator and an omnidirectional monopole antenna. The antenna was connected to the pulse generator, which was set to generate sub-nanosecond current pulses, typical of partial discharge signals. The radiated current pulse is received using off-the-shelf antennas connected to an oscilloscope. These pulses were recorded and saved throughout the measurement campaign. During measurement, no effort was made to suppress ambient noise and interferences, so that PD signals corrupted by noise/interferences could be acquired. Representative examples of the noise-corrupted PD signals acquired during the measurement campaign are shown in Figure 2. The PD signals are corrupted by the presence of noise. As a result, the desired time-domain characteristics of the signals are not clearly identified. The noise is modelled as white Gaussian noise (which includes quantization noise and random disturbances), wherein the frequency components are distributed over all frequency range while the signal of interest lies within a specific range of frequency. Extracting PD pulses from such noisy measurements before further analysis is therefore crucial. It is also important that this is done in such a way that the features of the PD pulse are preserved as much as possible. The noise component of the measured PD signals can be removed by the de-noising process. The stochastic and transient nature of PD signals demands sophisticated techniques for this process.

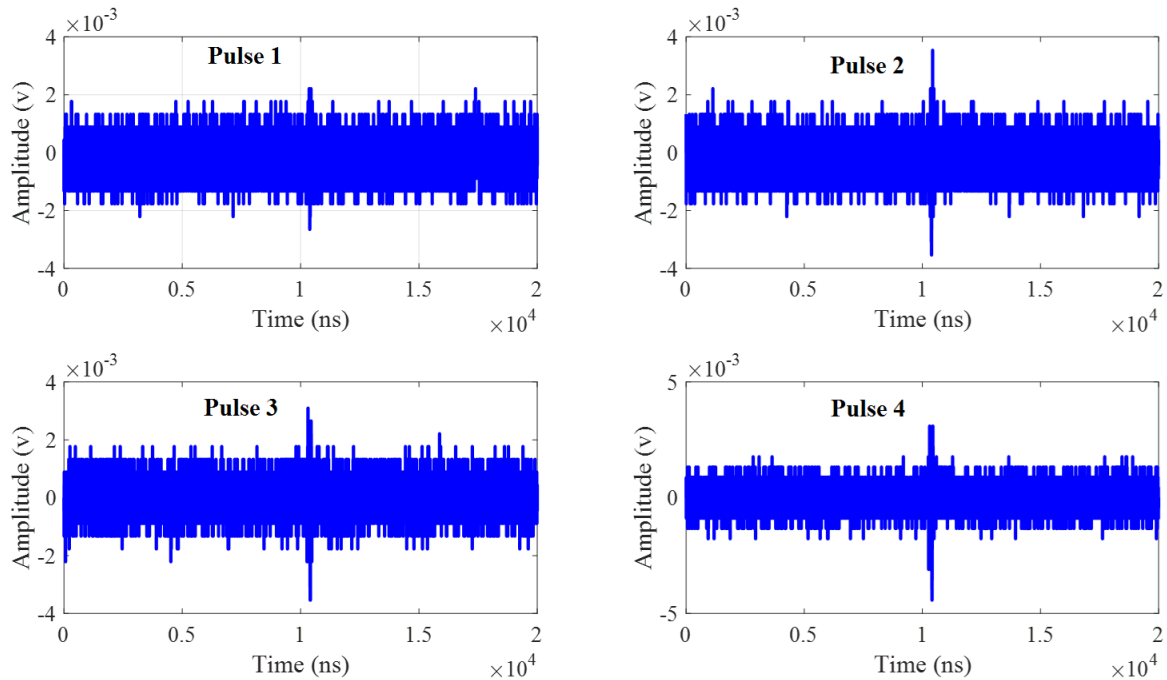

Figure 2. Measured PD signals

5. Results and Discussion

The noise-contaminated PD measurement shown in Figure 2 acquired during the measurement campaign is used to verify the effectiveness of the proposed denoising technique.

5.1. Proposed Wavelet-PCA PD Denoising Process

The PD signal denoising technique proposed in this paper is accomplished in two stages, namely, Wavelet decomposition and PCA. Figure 3 shows the flowchart for the proposed PD signal de-noising technique. The procedure for implementing the proposed denoising technique involves four steps:

1. Perform wavelet decomposition up to level J for all columns of the data. This step produces detail coefficients, D_1, \dots, D_J at level 1 and approximate coefficients A_j at all levels of decomposition.
2. Apply PCA on the approximate and detailed coefficients and select the appropriate number of useful principal components. This improves the wavelet result by retaining fewer informative principal components.
3. Apply thresholding to each detailed coefficient to remove the noise component of the measured PD signals.
4. Reconstruct the denoised signal from the simplified detail and approximate coefficients by inverting the wavelet transform.

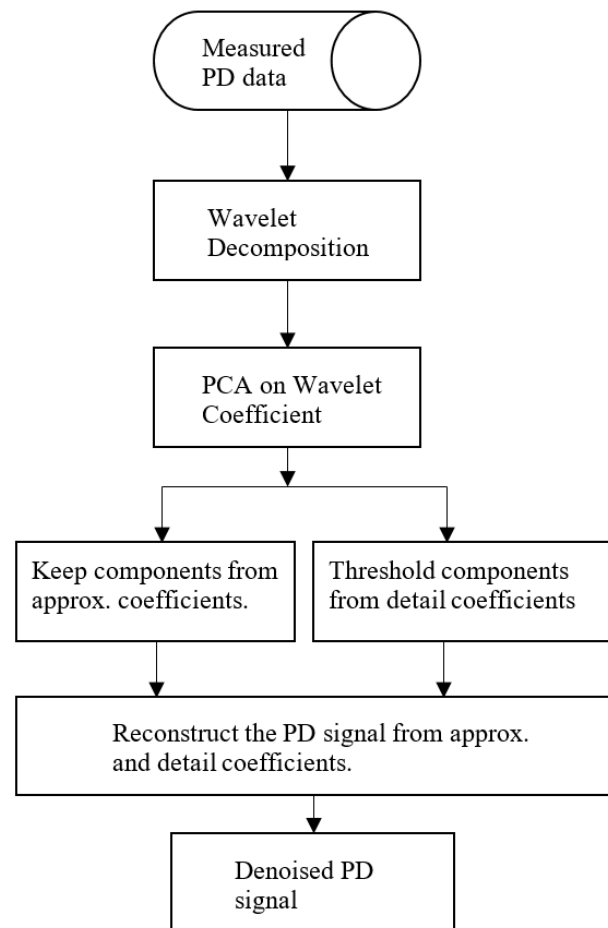

Figure 3. Flow chart of the wavelet-PCA de-noising

5.2. Wavelet Stage

In the first stage, the noisy PD signal is passed as an input to the Daubechies wavelet filter [23] and is decomposed into the wavelet coefficients (approximate and detail) to level 8. The Daubechies ‘mother’ wavelet is chosen because of the shared similarity with the partial discharge signal. The decomposition level is chosen as 8 to allow for sufficient resolution at lower frequencies to eliminate impulsive noise at such frequencies. Shallow decomposition can make it challenging to differentiate and separate partial discharge signals and low frequency interferences. The PD signal decomposition can be modelled as Equation 6.

$$\hat{p}(n) = \sum_{k=-\infty}^{+\infty} (p, \phi_{j,k}) \phi_{j,k}(n) + \sum_{j \leq J} \sum_{k=-\infty}^{+\infty} (p, \varphi_{j,k}) \varphi_{j,k}(n) \quad (6)$$

where ϕ is the scaling function and φ is the wavelet function. The approximate coefficients, $a_{j,k} = (x, \phi_{j,k})$, describe the overall waveform of the signal, whereas detail coefficients $d_{j,k} = (x, \varphi_{j,k})$, describe the fine localise features of the signal. In other words, the energy in the signal of interest is distributed amongst the higher scale coefficients whereas the lower scale coefficients contain the energy of the noise. Hence the lower scale detail coefficients correspond to the noisy part of the signal. In the second stage of wavelet transform, the lower scale detail coefficients are truncated from the process. This is achieved by using a predefined threshold τ . Thresholding eliminates the noisy component of the signal and thus highlights the important information. In PD de-noising, the most frequently used thresholding rule is soft thresholding, which shrinks all detail coefficients $d_{j,k}$ below τ to 0 [24]. In this paper, the universal fixed form of soft thresholding is used as defined in Equations 7 and 9 respectively. This selection is informed by the fact that PD measurements are often characterized by low signal-to-noise ratio (SNR).

$$\tau = \hat{\sigma} \sqrt{2 \log(N)} \quad (7)$$

where N is the length of the signal and $\hat{\sigma}$ the estimate of the noise standard deviation given by Equation 8.

$$\hat{\sigma} = \sqrt{2} \text{mad}(d_1) / 0.6745 \quad (8)$$

where $\text{mad}(d_1)$ is the median absolute deviation of the detail coefficients at level 1.

$$\rho_{\text{soft}}(x) = \begin{cases} x - \tau & x > \tau \\ 0 & x \leq \tau \\ x + \tau & x < -\tau \end{cases} \quad (9)$$

where x is the data and ρ is the threshold.

5.3. PCA Stage

In the second stage of the proposed denoising technique, the resultant wavelet coefficients are passed through PCA to filter out the remaining noise in the wavelet transformed signal. PCA was applied to both approximate and detail coefficients before thresholding. PCA serves as a second denoising layer to eliminate the noise and redundant components that escaped after the wavelet transform. This produces a cleaner PD signal. To select the optimal number of principal components to retain in this application, Kaiser's rule [25] was employed. In Kaiser's rule, components whose eigenvalues are greater than the average eigenvalue or have their 95% confidence limits encompassing the average eigenvalue are retained. This is because these components summarize more information than any of the original variables. To Denoising the wavelet coefficients using PCA, we evaluate the covariance matrix and use the eigenvalues to find the information in each coefficient. By removing the principal components with low variance, which represent noise, PCA can improve the signal-to-noise ratio and make it easier to identify the underlying structure in the data. This helps preserve the structure of the original PD signal after denoising. The final step involves the reconstruction of a denoised version of the original signal from the threshold coefficients using the inverse wavelet transform. Figure 4 shows the representative sample of the denoised PD signals used in this paper to demonstrate the effectiveness of the proposed wavelet-PCA denoising technique.

To understand the performance of the proposed denoising technique, we can only estimate the extent to which the noise is suppressed in our measurements because our experiment does not have a reference signal to compute signal-to-noise ratio. This is common with practical measurements. The extent of noise suppression is computed using Equation 10.

$$\text{Noise}_{\text{Reduced}} = 10 \log \log (|X(n) - P(n)|)^2 \quad (10)$$

For the four examples PD measured signals shown in Figure 2 and the corresponding denoised PD signals in Figure 4, the level of noise reduction using the wavelet-PCA denoising method is -7.87, -7.20, -4.68 and -3.22 dB respectively. From the denoised signal plots, it is seen that, the interferences that overlap in time with the PD signals have been completely removed. Further, the PD pulses recovered have not suffered distortion. Thus, this demonstrates the effectiveness of the wavelet-PCA method in denoising PD pulses.

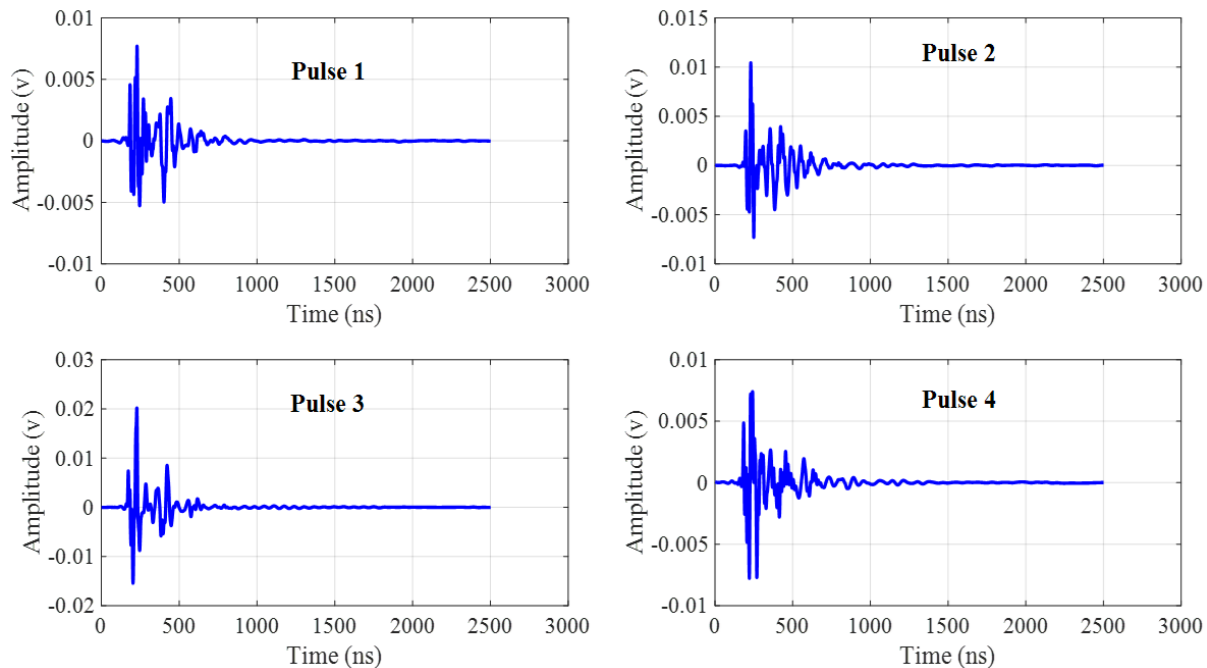

Figure 4. PD denoised signals

6. Conclusions

PD signals collected during on-site PD measurements are strongly influenced by noise. This paper presents a hybrid PD denoising method which combines wavelet decomposition technique and PCA algorithm. Our approach is to decompose the noisy PD signal using wavelet decomposition and then apply PCA to the wavelet coefficients generated. The principal components of the wavelet coefficients are then reconstructed to form the denoised signal. Analysis of the results for emulated PD waveforms reveals that, the proposed wavelet-PCA method is an effective PD denoising technique that can be used for on-line/on-site measurements. The additional PCA denoising effect removes more noise and also makes buried elements of the original signal visible. Thus, the proposed wavelet-PCA method was shown to be successful in rejecting all types of interferences, present in the measured signal. In addition to achieving acceptable levels of noise suppression, another notable feature of the proposed method was that it preserved the features of the PD pulses as much as possible. Suppressing the noise component in PD measurements and extracting PD signals helps in the quick and reliable identification of the PD sources responsible for insulation degradation in order to fully characterize the present state of the equipment. The limitation of the proposed PD denoising technique is related to the choice of the mother wavelet, and a number of decomposition levels. Future work will involve careful assessment and selection of the best mother wavelet and decomposition levels.

REFERENCES

- [1] International Standard, "60270, high voltage test techniques-partial discharge measurements," International Electrotechnical Commission, Ed. 3.1, 2015, pp 1-226. <https://webstore.iec.ch/publication/23841>
- [2] Nesbitt A., Stewart B., McMeekin S., Conner S., Gamio J., Liebeck-Lien K., Kristiansen H., S. Krakenes, "A novel approach to high voltage substation surveillance using radio frequency interference measurement," Electrical Insulation Conference, Montreal, QC, Canada, pp. 159-163, Jul., 2009.
- [3] Kurtz, E. B., Shoemaker T. M., J. E. Mack, The lineman's and cableman's handbook, Ed. 12, McGraw-Hill, 2012, pp. 1 - 61.
- [4] Siew, W., Liu Y., Musa, B., Mir F., Y. Wang, "Basis for a wireless network for EMC measurement in Electrical Substations," IEEE International Symposium on Electromagnetic Compactability, 2007. DOI:10.1109/ISEMC.2007.53.
- [5] Wiggins C., S. Wright, "Switching transient fields in Substations," IEEE Transaction on Power Delivery, vol. 6, no. 2, pp. 591- 600, 1991. <https://doi.org/10.1109/61.131116>.
- [6] Bhatti, S. A., Shan, Q., Atkinson, R., Vieira M., I. Glover, "Vulnerability of zigbee to impulsive noise in electricity substations," General Assembly and Scientific Symposium 2011 XXXth USRI, Istanbul, Turkey August, 2011. <https://doi.org/10.1109/URSIGASS.2011.6050729>
- [7] J. Simms, "Sources of electromagnetic emission," IEE Colloquium on Electromagnetic compatibility in the Electricity Supply industry, 1990.

- [8] Madi, G., Sacuto F., Vrigneau B., Agba B. L., Pousset Y., Vauzelle R., F. Gagnon, "Impacts of impulsive noise from partial discharges on wireless system performance," *EURASIP Journal on Wireless Communications and Networking*, vol. 2011, no. 186, pp. 1-12, 2011. <https://doi.org/10.1186/1687-1499-2011-186>
- [9] Yusoff N. A., Isa M., Hamid H., Adzman, M. R., Rohani M. N. K. H., Chai C. Y., N. N. Ayop, "Denoising Technique for Partial Discharge Signal: A Comparison Performance between Artificial Neural Network, Fast Fourier Transform and Discrete Wavelet Transform," *IEEE International Conference on Power and Energy*, Melaka, 2016. DOI: 10.1109/PECON.2016.7951579
- [10] Satish L., B. Nazneen, "Wavelet-based Denoising of Partial Discharge Signals Buried in Excessive Noise and Interference," *IEEE Transactions on Dielectrics and Electrical Insulation*, vol. 10, no. 2, pp. 354-367, 2003. DOI: 10.1109/TDEI.2003.1194122
- [11] Evagorou D., Kyprianout A., Lewin P. L., Stavrou, A., Efthymiou V., G. E. Georghiou, "Evaluation of Partial Discharge Denoising using the Wavelet Packets Transform as a Preprocessing Step for Classification," *Annual Report Conference on Electrical Insulation Dielectric Phenomena, CEIDP*, 2008. pp. 387-390. <https://doi.org/10.1109/CEIDP.2008.4772794>
- [12] Mng J. C. P., M. Mehralizadeh, "Forecasting East Asian Indices Futures via a Novel Hybrid of Wavelet-PCA Denoising and Artificial Neural Network," *PLOS One*, vol. 11, no. 6, 2016. <https://doi.org/10.1371/journal.pone.0156338>
- [13] Mohanty S., Gupta K. K., K. S. Raju, "Adaptive fault identification of Bearing using empirical mode decomposition principal component analysis-based Average kurtosis technique," *IET Science, Measurement & Technology*, vol. 11, no. 1, pp. 30-40, 2017. DOI: 10.1049/iet-smt.2016.0121
- [14] Yuan, Y., Riccardo T., Igor Simone S., Hongjie L., X. Yan-Zhao, "An Automatic Tool for Partial Discharge Denoising via Short-Time Fourier Transform and Matrix Factorization," *IEEE Transaction on Instrumentation and Measurement*, vol. 71, 2022. DOI: 10.1109/TIM.2022.3216583
- [15] Tray J. B., Herrera R. H., M. Van der Baan, "Analysis of Time-varying Signals using Continuous Wavelet and Synchrosqueezed Transforms," *Philosophical Transaction of the Royal Society A*, vol. 376, no. 2126, pp. 1-16, 2018. <https://doi.org/10.1098/rsta.2017.0254>
- [16] Osadchiy A., Kamenev A., Saharov V., S. Chernyi, "Signal Processing Algorithm Based on Discrete Wavelet Transform," *Designs*, vol. 5, no. 41, pp. 2-13, 2021. <https://doi.org/10.3390/designs5030041>
- [17] Li P., Li Y., Wang H., D. Lin, "Research and Analysis of One-dimensional Discrete Wavelet Transform," *4th International Conference on Advanced Electronic Materials, Computers and Software Engineering (AEMCSE)*, Changsha, 2021.
- [18] Tan L., Wu F., W. Li, "Image Compression and Reconstruction Based on PCA," *Journal of Physics: Conference Series*, 2021.
- [19] Singh N., A. K. Bhandari, "Principal Component Analysis-Based Low-light Image Enhancement Using Reflection Model," *IEEE Transactions on Instrumentation and Measurement*, vol. 70, pp. 1-10. DOI: 10.1109/TIM.2021.3096266
- [20] Does, M. D., Olesen J. L., Harkins K. D., Srradas-Duarte T., Gochberg D. F., Jespersen S. N., N. Shemesh, "Evaluation of Principal Component Analysis Image Denoising on Multi-Exponential MRI Relaxometry," *Magn Reson Med.*, vol. 81, no. 6, pp. 3503-3514, 2019. <https://doi.org/10.1002/mrm.27658>
- [21] J. Shlens, "A tutorial on principal component analysis," *ArXiv preprint*, 2014.
- [22] L. I. Smith, "A tutorial on principal components analysis," *Tech. Rep.*, 2002.
- [23] Petrarca C., G. Lupo, "An improved methodological approach for denoising of partial discharge data by the wavelet transform," *Progress in Electromagnetic Research*, vol. 58, pp. 205-217, 2014. DOI:10.2528/PIERB14012006
- [24] Mostacci E., Truntzer C., Cardot H., P. Ducoroy, "Multivariate denoising methods combining wavelets and principal component analysis for mass spectrometry data," *Proteomics*, vol. 10, no. 14, pp. 2564-2572, 2010. <https://doi.org/10.1002/prca.201090072>
- [25] D. A. Jackson, "Stopping rules in principal components analysis: A comparison of heuristical and statistical approaches," *Ecology*, vol. 74, no. 8, pp. 2204-2214, 1993. <https://doi.org/10.2307/193957>