

# Embodied and Operational Energy Assessment Using Structural Equation Modeling for Construction Project

Subrata Aditama K. A. Uda<sup>1,\*</sup>, Mochamad Agung Wibowo<sup>2</sup>, Jati Utomo Dwi Hatmoko<sup>2</sup>

<sup>1</sup>Department of Civil Engineering, Faculty of Engineering, Palangka Raya University, Palangka Raya, Indonesia

<sup>2</sup>Department of Civil Engineering, Faculty of Engineering, Diponegoro University, Semarang, Indonesia

*Received February 8, 2021; Revised April 6, 2021; Accepted April 18, 2021*

## **Cite This Paper in the following Citation Styles**

**(a):** [1] Subrata Aditama K. A. Uda, Mochamad Agung Wibowo, Jati Utomo Dwi Hatmoko , "Embodied and Operational Energy Assessment Using Structural Equation Modeling for Construction Project," *Civil Engineering and Architecture*, Vol. 9, No. 3, pp. 670-681, 2021. DOI: 10.13189/cea.2021.090310.

**(b):** Subrata Aditama K. A. Uda, Mochamad Agung Wibowo, Jati Utomo Dwi Hatmoko (2021). *Embodied and Operational Energy Assessment Using Structural Equation Modeling for Construction Project*. *Civil Engineering and Architecture*, 9(3), 670-681. DOI: 10.13189/cea.2021.090310.

Copyright©2021 by authors, all rights reserved. Authors agree that this article remains permanently open access under the terms of the Creative Commons Attribution License 4.0 International License

**Abstract** The construction industries had a significant role as emission gas contributors through direct activities, such as the construction process, the operation and demolition of the building, and indirect activities, which is the designing process to decide the types of materials and the shapes of the building. This paper aimed to create an embodied and operational energy assessment concept based on a project life cycle using qualitative methods through a research questionnaire. In the questionnaire, there were 18 indicators based on a literature review relating to embodied and operational energy within the scope of the project life cycle (initiation, design, construction, and operation). Indicator assessment used a Likert scale and was analyzed by Structural Equation Modeling Partial Least Squares. Respondents in this study include consultants, contractors, and stakeholders. The results of the study showed a significant relationship between the initiation and design phases of the construction phase and the operational phase to minimize energy. Stakeholder commitment to the environment and planning that prioritizes energy efficiency (embodied and operational energy) had the highest T-Statistic values of 100.479 and 61.581 with a 95% confidence level. This showed the role of stakeholders and designers is crucial to the reduction in energy embodied and operational during the project life cycle, so that awareness and commitment are needed in realizing green construction.

**Keywords** Embodied and Operational Energy, Project Life Cycle, Energy Assessment, Structural Equation Modeling Partial Least Squares

## **1. Introduction**

The high-temperature changes are mostly caused by the increase of carbon dioxide and other man-made emissions to the atmosphere. The UNEP data stated that the construction projects spent 40% of energy, 25% of water, and 40% of global resources that were directed to the atmosphere for 1/3 of the world's emission; besides there were 60% of the world's electricity that was consumed during the building operational phase [1]. The energy of material building and construction process consumed most of the energy of the buildings towards their life cycle. There were three ultimate ways to decrease energy consumption, i.e., decreasing the utilization of the building's energy, replacing fossil fuel with renewable energy, and increasing energy efficiency. Accordingly, decreasing the energy contained in the building had become a concern as one of the issues to decrease the carbon dioxide emission and global warming [2].

The embodied energy was the total of energy-related, directly or indirectly, to the delivery of goods or services [3]. However, some researches showed that there were some different perspectives to define the embodied energy on the chosen boundaries of the study. Three common choices were cradle-to-gate, cradle-to-site, and cradle-to-grave [4]. The embodied energy was the energy consumed by all processes related to the production of the buildings, mining, natural resources' processing, and manufacturing, transporting, and delivering products. Transportation was the main element of the construction of material energy [2,5]. Embodied Energy and Carbon were the energy expended during the construction process,

focusing on the energy from the manufacturing process, distribution/ supply, transportation, and tools utilized during the building process. Commonly, this energy used fossil fuels, such as factories and vehicles. The operational energy was from the energy expended during the operation of the building within 50 years. The operational energy included the utilization of electricity, air conditioning, kitchen, and so forth. The operational energy contained 80%-90%, while the embodied energy was between 10% to 20%. The requirements of operational energy in buildings include the amount of energy used to protect the environment inside the building, in other words, all energy was imported into the system to operate lights, elevators and escalators, ventilation systems, heating, and cooling systems, water heaters, and pumping systems. These energies included the energy coming from electricity, gas, and fuel, for instance, oil and coal [6].

This research aims to create an assessment concept of embodied and operational energy according to the project life cycle (PLC) by formulating the assessment indicators from the result of the literature study and interview observation to the experts in the construction field. This model is supposed to be a basic concept to evaluate and control all phases, starting from the phase of Initiation, Design, Construction, and Operation. This model can be applied to the Consultants and Contractors as an effort to minimize the embodied energy in the construction field.

## 2. Project Life-Cycle and Life-Cycle Energy Concepts

### Project Life Cycle (PLC)

The project life cycle is the stages of project activities starting from the initiation/idea/conceptual to the project which is declared completed and operationalized, where each stage has its own characteristics. The project life cycle has 4 stages: initiation, design, construction, and operational [7]. The characteristics of several projects differ in each project's life cycle. The Planning stage includes conception design, preliminary evaluation, then the Design stage involves the initial design and detailed design, the construction stage includes the project building production project, the Utilization stage continues to refer to the use or operation of the building owner or tenant and finally the decommissioning stage consists of demolition and recycling building or material [8].

### Life Cycle Energy (LCE)

The energy life cycle is the stages of development activities that utilize energy in each of its activities starting from the production and construction process to the building demolition. The buildings, materials, and components consume almost 40% of global energy every day in their energy life cycle, such as production and materials procurement, construction, operation, and demolition [10]. Embodied energy is the energy contained in the buildings and building materials for the process of

production, construction implementation, buildings' demolition, and the disposal of remaining materials [9,11]. The high level of embodied energy shows the higher pollution level at the end of production as energy consumption mostly produces emission. Concrete, aluminum, and steel are materials that contain high energy and produce high CO<sub>2</sub> emission [12].

Operational energy includes the numbers of energy released to operate lighting, lift and escalator, ventilation system, heating and cooling system, pumping system used to support the activities of all buildings. The operational energy is mostly related to stable internal environmental maintenance [6]. The target of this energy utilization will be varied. It depends on the needs and functions of the building and the surrounding.

## 3. Methodology

This research employed a qualitative method by doing literature studies, observation, and some interviews with the experts in the construction services, such as consultants, contractors, and stakeholders. The result of the literature studies and observation was used to identify some variables and elements to compile the indicators of embodied and operational energy assessment. Those indicators were arranged into questionnaires. The questionnaires were given to the experienced respondents and experts in the construction's activities.

There are 18 statements (table 1 and appendix A) that represent energy optimization based on the project life cycle from the results of the literature study. This statement will be filled in using a Likert scale (table 2) by the respondent. This research was taken in Indonesia. The respondents were the consultants and contractor companies of construction services, which were taken from the list of the members of Green Building Council Indonesia (GBCI), which consisted of 89 companies. The result of the questionnaires was processed using Structural Equation Modeling (SEM SmartPLS Version 3.0) [13].

**Table 1.** Phase and Indicator

No	PLC Category	Indicator
1	Initiation	2
2	Design	4
3	Construction	10
4	Operational	2
Total		18

**Table 2.** Degree of Importance

No	Category	Likert Scales
1	Strongly Disagree	1
2	Disagree	2
3	Neutral	3
4	Agree	4
5	Strongly Agree	5

The indicators of embodied and operational energy assessment were obtained according to the literature study and were grouped according to the variables of each step in the Project Life Cycle (PLC) as follows:

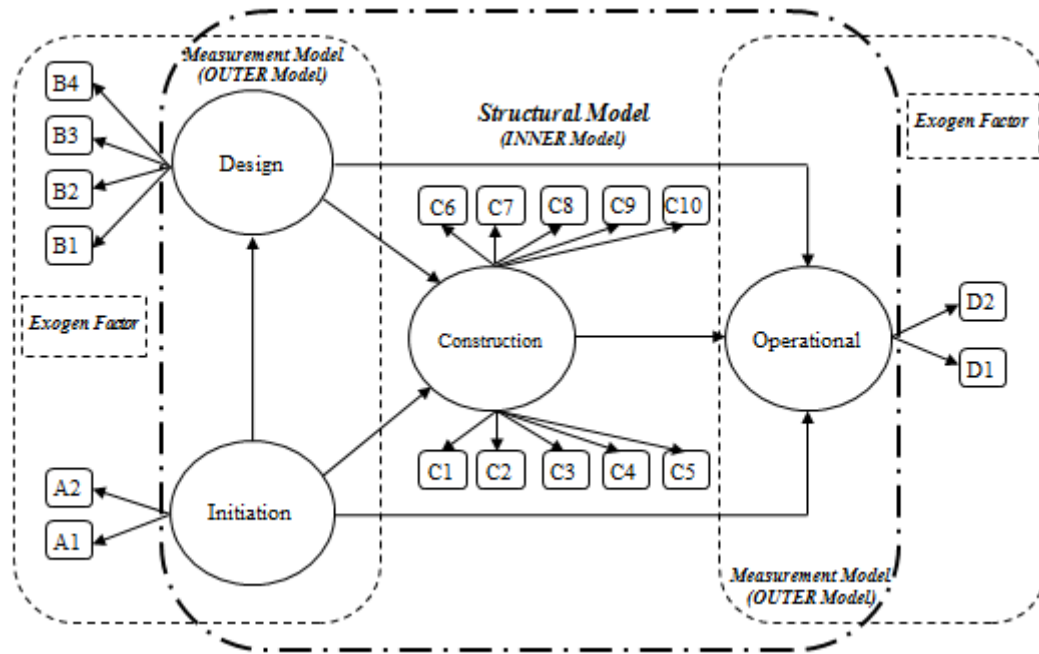

Figure 1. The concept of the Embodied energy and Operational Energy Assessment Model

Table 3. Respondent's profile

Participants	Experience in years			Amount	%	Participants by Occupation		
	< 10	10 - 15	> 15			Position	Amount	%
Stakeholder	2	3	5	10	14	CEO/GM	25	13.5
Consultant	2	8	19	29	39	PM/CM	39	52.7
Contractor	4	12	19	35	47	SPV/AE	10	33.8
Total	8	23	43	74	100			
%	11	31	58			Total	74	100

Note: CEO = Chief Executive Officer, GM = General Manager, PM = Project Manager, CM = Construction Manager, SPV = Supervisors, AE = Assistant Engineer

Figure 1 showed the concept of the embodied energy and operational energy assessment model which was used to observe the relationship between each variable. This concept was divided into 2 sub-models. First, the structural Model (Inner Model) showed the estimation strength between the latent and construct variables (Variable of Initiation, Design, Construction, and Operation). The Measurement Model (Outer Model) showed how the manifest or observed variable (Element and indicator) represented the latent variable to be measured. In the Inner Model, two factors were influencing the latent variables. The exogen factor was the cause variable or variable without being started by other variables using arrows towards other variables (the latent endogenous variable), while the Endogen factor was the latent variable that was influenced by the exigent variable. Those concepts were the first step before being tested using Partial Least Squares (PLS) to create the new model.

## 4. Results and Discussion

The data collection of the research was collected by sending the questionnaires to the respondents, doing the observation, and directly contractors and consultants of construction services. There were 74 respondents or about 83% who sent back the questionnaires which were proper to be analyzed. The following was the result of the respondent's data analysis (table 3).

Table 3 showed the respondent who was involved in this research. There were 47% of contractors, 39% of consultants, and 14% of stakeholders. There were 58% respondents which had working experience for more than 15 years; 31% respondents which had 10-15 years of working experience, and only 11% respondents which had less than 10 years of working experience. Based on the respondent position, 52.7% came from the project manager (PM) and construction manager (CM), 33.8% came from the supervisor (SPV) and technical assistant (AE), and 13.5% of respondents held the position of the chief executive (CEO) and general manager (GM) of the Company.

**Table 4.** The Result of the Structural Model Test (Inner Model)

Path Coefficient (Indicators)	Original Sample (O)	Mean Sample (M)	Standard Deviation (STDEV)	T Statistic (IO/STDEV)	P Values
INITIATION→ Regulations and Policies (A1)	0.900	0.900	0.027	33.603	0.000
INITIATION→Commitment of the stakeholders to the environment (A2)	0.950	0.952	0.009	100.479	0.000
DESIGN→Design of low and zero waste energy materials (B1)	0.875	0.871	0.028	31.638	0.000
DESIGN→Recycle and Renewable of wasted materials (B2)	0.850	0.850	0.030	27.889	0.000
DESIGN→Design of Energy Efficiency (Embodied and Operational Energy) (B3)	0.933	0.934	0.015	61.581	0.000
DESIGN→Design of Flexibility and Efficiency of the buildings (B4)	0.932	0.932	0.016	58.422	0.000
CONSTRUCTION→Supply Chain Materials (C1)	0.836	0.836	0.037	22.618	0.000
CONSTRUCTION→Management of Transportation System (C2)	0.829	0.832	0.045	18.450	0.000
CONSTRUCTION→Construction Method (C3)	0.873	0.873	0.027	31.905	0.000
CONSTRUCTION→Efficiency and Optimization of Heavy Vehicles(C4)	0.816	0.814	0.052	15.768	0.000
CONSTRUCTION→Utilization of Materials for the Supporting Buildings (C5)	0.746	0.750	0.054	13.775	0.000
CONSTRUCTION→Efficiency of Electricity Energy and Utilization of Alternative Energy (C6)	0.870	0.870	0.028	31.058	0.000
CONSTRUCTION→ Repeated Works (C7)	0.742	0.740	0.065	11.414	0.000
CONSTRUCTION→Skill of the Workers (C8)	0.742	0.745	0.050	14.860	0.000
CONSTRUCTION→Waste Management (C9)	0.867	0.870	0.023	38.100	0.000
CONSTRUCTION→ Reuse & Recycle Materials (C10)	0.837	0.839	0.028	29.432	0.000
OPERATIONAL→ Operational buildings (D1)	0.977	0.978	0.005	211.231	0.000
OPERATIONAL→Maintenance, Repair, Replacement & Refurbishment (D2)	0.877	0.879	0.025	34.802	0.000
INITIATION→ DESIGN	0.732	0.737	0.064	11.487	0.000
INITIATION→ CONSTRUCTION	0.263	0.257	0.096	2.744	0.006
INITIATION→ OPERATIONAL	0.251	0.245	0.117	2.148	0.032
DESIGN→ CONSTRUCTION	0.642	0.645	0.089	7.236	0.000
DESIGN→ OPERATIONAL	0.254	0.273	0.134	2.186	0.043
CONSTRUCTION→ OPERATIONAL	0.618	0.620	0.140	4.417	0.000

According to the result of the structural model evaluation in Table 4, it was found that almost all indicators had influenced the variables. The influence of the stage of initiation to the indicator of the stakeholder's commitment to the environment had a significant relation, in which the T-statistic value was 100.479 and the P-value was 0.000. In the stage of design, the most influencing indicator was the design of energy efficiency (embodied and operational energy), in which the T-statistic value was 61.581 and the P-value was 0.000, while in the stage of construction, the most influencing indicator was Waste Management, which T-statistic value was 38.100 and the P-value was 0.000. The last, the stage of operation, the operational building indicator influenced the T-statistic value significantly, that was 211.231 and the P-value was 0.000. The structural model test (Inner Model) decided the

value of T-value and P-value. The minimum limit value allowed for the T-value was 1.96 for two-tailed, while the P-value might be lower than the significant error value. In this research, the significant error ( $\alpha$ ) was 0.05 or 5% [14].

The energy assessment model can be formulated into an equation with a constant value based on the path coefficient in the original sample column in Table 4. The original sample shows a value of 0.9 or has a respondent confidence level of 90% of the A1 indicator in an effort to reduce energy consumption in the Initiation phase. Likewise with the A2 indicator which shows a value of 0.95 or 95% of the respondent's confidence level. Furthermore, each respondent shows the value of the level of confidence which is used as the basis for the formulation of the level of assessment. The equation for the energy valuation model in a construction project (Energy Assessment Model in

Construction Project (EAMCP)) is formulated as follows:

$$EAMCP = 0.9A1 + 0.95A2 + 0.875B1 + 0.85B2 + 0.933B3 + 0.932B4 + 0.836C1 + 0.829C2 + 0.873C3 + 0.816C4 + 0.746C5 + 0.87C6 + 0.742C7 + 0.742C8 + 0.867C9 + 0.837C10 + 0.977D1 + 0.877D2 \quad (1)$$

Where; A1 = Regulations and Policies, A2 = Commitment of the stakeholders to the environment, B1 = Design of low and zero waste energy materials, B2 = Recycle and Renewable of wasted materials, B3 = Design of Energy Efficiency (Embodied and Operational Energy), B4 = Design of Flexibility and Efficiency of the buildings, C1 = Supply Chain Materials, C2 = Management of Transportation System, C3 = Construction Method, C4 = Efficiency and Optimization of Heavy Vehicles, C5 = Utilization of Materials for the Supporting Buildings, C6 = Efficiency of Electricity Energy and Utilization of Alternative Energy, C7 = Repeated Works, C8 = Skill of the Workers, C9 = Waste Management, C10 = Reuse & Recycle Materials, D1 = Operational buildings, D2 = Maintenance, Repair, Replacement & Refurbishment.

Figure 2 showed the relation between variables. The relation between the stage of initiation towards the stage of design had a T-statistic value of 11.487 and a P-value of 0.000. It meant that the stage of initiation strongly influenced the energy decrease towards the stage of design. The stage of initiation towards the stage of construction got the T-statistic value of 2.744 and the P-value of 0.000. It meant that the stage of initiation strongly influenced the energy decrease towards the stage of construction. The

stage of initiation towards the stage of operation had the T-statistic value of 2.148 and the P-value of 0.000. It meant that the stage of initiation significantly influenced the energy decrease towards the stage of operational.

The stage of design to the stage of construction had a T-statistic value of 7.236 and a P-value of 0.000. it meant the stage of design was significantly influencing the energy decreasing in the stage of construction. The stage of design to the stage of operational had a T-statistic value of 2.186 and a P-value of 0.043. It meant that the stage of design was significantly influencing the energy decreasing in the stage of operation. The stage of construction towards the stage of operational was got the T-statistic value of 4.417 and the P-value of 0.000. It meant that the stage of construction significantly influenced the energy decreasing towards the stage of operation. The result of the stage of design towards the stage of operation showed the different views from other researchers, where the activities of building operation were strongly dependent on the design that had been planned [15,16,17].

Most of the building operations would follow the first design of the building, but sometimes the design was changing and adjusting to the needs of users as the owner of the building. This condition often happened on the buildings and housings where the renovation could change to half of the first design. The method to decrease the embodied energy in the building was by utilizing the local materials with similar durability, low design, maintenance, and flexibility while using the building and the right decision on the material design of the building [18].

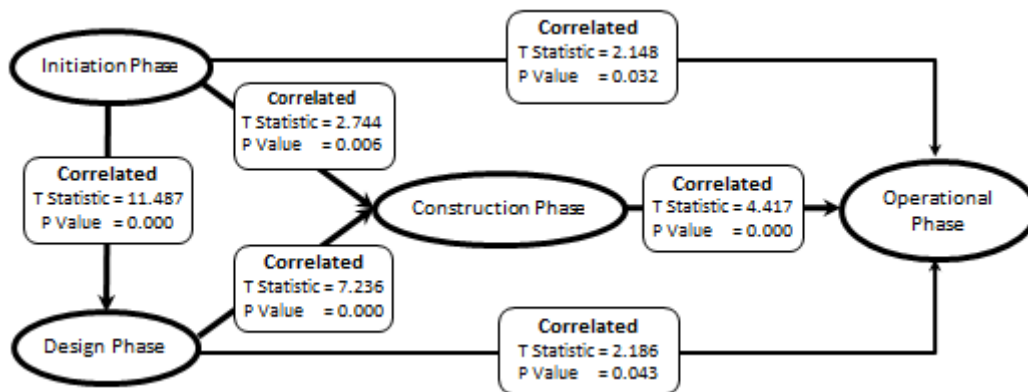

Figure 2. The Correlation of Energy Valuation Model according to the Project Life Cycle (PLC)

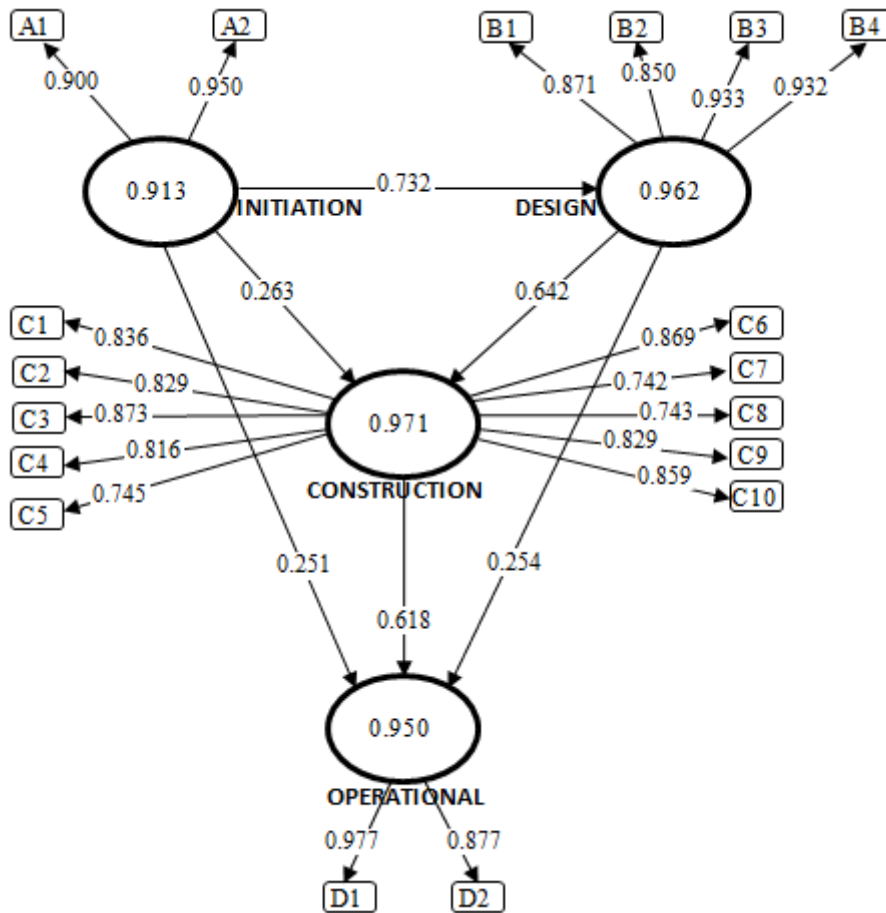

Figure 3. The Valuation Model of Embodied Energy and Operational Energy according to Project Life Cycle

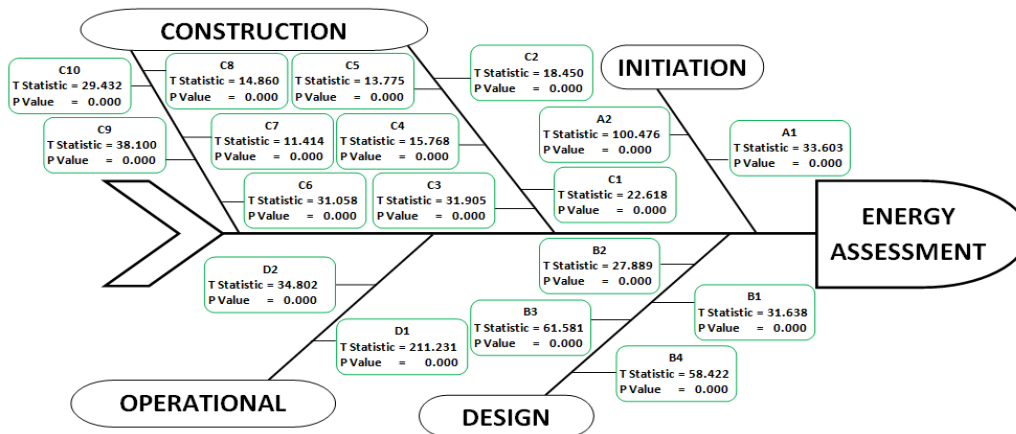

Figure 4. The Fish Bone Diagram of Embodied Energy and Operational Energy

Figure 3 showed the last model of the result of the PLS analysis. This new model showed that each indicator had varying values to the latent variables, where the lowest indicator value was on indicator C7, which was 0.742. This value was higher than the level of a significant error, which was 0.05. Thus, the level of trust in this indicator was more than 95% and could be used as the indicator of the design variable.

Figure 4 showed the fishbone model for the valuation of

embodied energy and operational energy on the project life cycle (PLC). The value of T-Statistic and P-Value in all valuation indicators exceeded the significance value (two-tailed) T-value 1.96 (significance level = 5%) and P-value  $> \alpha = 0.05$  or 5%. It showed all indicators influenced each aspect, so they could be used for the energy valuation model.

This research showed that the efforts to minimize the embodied energy and operational energy in the life cycle of

construction had to be started from the Initiation stage. The role of stakeholders and the Government determined the commitment to decrease energy usage and concern to the environment [11,19]. This commitment could be realized by issuing the regulations and requirements on the construction activities and written as one of the Paragraphs on the contract documents. The public policy became the key factor to develop a further strategy and build protocols to reuse the existing buildings to utilize the embodied energy [17,20]. Besides, the government could offer some benefits, such as ease of licensing, and the reward to the constructors and the building managers. It aimed to encourage investors, constructors, and consultants to the concern of the eco-friendly building and efficiency of energy utilization.

In the stage of design, the role of consultant designers and supervisors decided the form of eco-friendly buildings. The energy-efficient design would influence the level of energy utilization. The building design, using sunlight as the natural light during the day, decreased the utilization of electrical energy; besides, the right façade design would decrease the high temperature from outside the building so it would minimize the utilization of air conditioners (AC) [16,17]. Still, in this stage of design, it was time to decide which materials to use [19,21]. The more natural materials (recycle and renewable materials) they chose, the more energy they would save. As the materials produced by the factories used too much energy, both fossil and non-fossil [22]. The role of the architect to design the low embodied energy buildings at the building operational would create a big impact to decrease the embodied energy level during the age of the buildings [20].

In the phase of construction, the efforts to optimization the highest energy could be done on the construction implementation method, which well-prepared method would decrease most energy in the construction process. For example, the method of heavy vehicles' choices, management of operational schedule, and the skills of operators would decide the productivity to optimize fuel utilization as the main energy. The main components of energy use at the construction phase consist of embodied energy in building materials and energy obtained from production activities, such as transportation, equipment, processing, and utilization of renewable energy [2]. Besides, a good waste management system would minimize the wasted materials and facilitate the choice of the material that could be recycled, renewed, and discarded, as well as the choice and management of efficient transportation.

The operational phase is the phase that consumes the most energy during the project life cycle. It was caused by the age of buildings, which were about 30-50 years, and about 80% of the total energy consumption in the building life cycle [6,15]. On the conventional buildings, the total of embodied energy was about 10%-20%, while 80%-90% of energy was on the stage of operation, and less than 1% was

contained on the maintenance and the last life cycle of the building [23]. It was proven by the number of validity levels in the research (T-statistic = 211.231). The efforts to decrease the energy utilization on the building operation could be done by using the energy-saving materials, especially electricity, and alternative energy utilization, such as sunlight energy as the electrical energy for water heater or lightings, especially around the building and streets. In the activity of building maintenance, they should utilize the energy-saving and eco-friendly tools and materials so the energy utilization could be optimized during the age of the building.

According to several studies, it is stated that energy optimization should be carried out in the pre-construction and construction phases which will directly affect a significant reduction in the operation phase [2,24]. The Embodied energy control in building materials used for building construction can have an impact efficiency of up to 60% of the energy life cycle. This efficiency has a significant effect on energy reduction during the operational period [25]. The role of the designer in designing the building has a strategic influence in reducing the overall energy, especially the energy efficiency of the mechanical and electrical systems used during the operation of the building [26]. Besides, an energy life cycle approach to construction projects in designing buildings that prioritize energy efficiency and are environmentally friendly will directly impact environmental sustainability [27]. This research is in line with the results obtained where the initiation and design phases will significantly contribute to efforts to minimize energy consumption during the construction and operational phases of a building.

## 5. Conclusions

The initiation and design phases are the initial stages in the project life cycle that directly affect the construction and operational processes of the building. Energy efficiency measures in the initiation and design phases will have a direct impact on reducing energy consumption in the next phases.

The highest value on the operational variable by using the operational building indicator where the T-Statistic value was 211.231 and P-value was 0.000, meaning that the item significantly influenced the energy decrease, especially the operational energy. Furthermore, on the initiation variable with the stakeholder's commitment to the environment where the T-statistic value was 100.479 and the P-value was 0.000, it meant that the commitment of stakeholders to the environment significantly influenced the energy decrease for both embodied and operational energy. There is a significant relationship between the initiation phase, the design phase, the construction phase, and the operational phase where the highest T-statistic

value is 11.487 and the lowest is 2.148, and the highest P-value is 0.043 and the lowest is 0.000. All of these values are above the T-value of 2.00 and below the P-value  $> \alpha = 0.05$  or 5%.

This embodied energy research model could be used as a basis to create an evaluation system to control the value of embodied energy based on the project life cycle. This model also could be developed to find out how many design concepts optimize the value of embodied energy or could be used as forms of check/list control. While at the time of construction, it could be used as the guidelines of energy-saving activities, so the embodied energy could be decreased in each worker's activity, implementation method, tool selection, and its operational, and waste management.

Based on the results of the analysis, it shows that all the assessment indicators in this model can be used as a basic concept for making evaluation modules and work

standards as well as assessments to minimize the embodied energy under the project life cycle. For further research, a more in-depth study of energy use in each phase (initiation, design, construction, and operational) is needed, to obtain the right strategy in minimizing energy consumption during the project life cycle.

## **Acknowledgments**

We extend the gratitude toward the Department of Public Works of Special Region of Yogyakarta Province, the Department of Public Works of Central Java Province, the Doctoral Program of Faculty of Engineering of Diponegoro University, the Contractors and the Consultants as the members of Green Building Council of Indonesia (GBCI).



## Appendix A

**Table Appendix A: The Variable, Element, and indicator of the Embodied and Operational Energy Assessment base on literature review**

No	Variables	Elements (Codes)	Codes	Indicator Assessments	References
1	Initiation Phase	Regulations and Policies (A1)	A1.1 The Government's regulations/ policies to build by concerning energy efficiency and environmentally friendly. A1.2 The agreement/ contracts referred to the regulations concerning the environmental factors and energy conservation. A1.3 The commitment of the stakeholders to realize the environmentally friendly and energy-saving buildings. A1.4 The designs of the buildings that gave priority to sustainable concepts. A1.5 The implementation of the development followed the Government's standard.		EBC Annex 57, 2016; Fuertes, 2017; Malmqvist et. al, 2018; Balouktsi & Lutzkendorf, 2016; Uda et. al, 2020.
		The commitment of the stakeholders to the environment (A2)	B1.1 Financial profit during the life of the building. B1.2 Participated in the Government's program to decrease energy and emission. B1.3 Benchmarking and piloting the low embodied energy buildings. B1.4 Preparation for Term Of Reference (TOR) that concerned with the environmentally friendly principles and energy efficiency. B1.5 Had the value-added to the market buildings. B1.6 Buildings and their components could last longer and adaptable were profitable.		Fuertes, 2017; Balouktsi & Lutzkendorf, 2016; Dixit, 2017; Gregory et.al, 2009;Feng et al., 2016; Uda et. al, 2020.
2	Design Phase	The low design materials of embodied energy and waste (B1)	A2.1 Designing the specification of low materials of embodied energy. A2.2 Designing low waste material buildings. A2.3 Designing the buildings that maximized natural material utilization. A2.4 Designing the buildings that maximized the innovation materials utilization. A2.5 Designing the types of materials that were easy to recycle. A2.6 Designing to minimize the utilization of high embodied energy materials, such as iron, steel, and concrete. A2.7 Designing the materials that utilized low energy and emission transportation. A2.8 Designing the materials that had higher resistance and lower maintenance during the age of the building.		Dixit et.al, 2012; GBC Indonesia, 2013; EBC Annex 57, 2016; Birgisdottir et.al, 2017; Pöyry et.al, 2015; Hammond et.al, 2008; Usep et.al, 2014; Holtzhausen, 2007; Crowther, 1999; Malmqvist et. al, 2018; Kumanayake R & Luo H.,2017; Uda et. al, 2020.
		Recycle and Renewable wasted materials (B2)	B2.1 Designing the buildings that utilized the recycle materials. B2.2 Designing the buildings that used innovative materials with low embodied energy. B2.3 Designing the buildings that used recycled materials for new buildings. B2.4 Designing the buildings that were easier to classify the materials' components to be recycled and renewable.		Holtzhausen, 2007; Crowther, 1999; Malmqvist et. al, 2018; Dixit et.al, 2010;Feng et al., 2016; Uda et. al, 2020.
		The Design of Efficiency and Embodied Energy (B3)	C2.1 Designs that featured the low embodied energy structures/ elements. C2.2 The building's design that utilized natural energy as the main energy. C2.3 The building's design that minimized the energy by applying the passive system, such as utilizing the electricity for lightings and air conditioning. C2.4 Designing lean construction. C2.5 Integrating the BIM concept to the design's step to prevent the adverse environmental effects and decrease the energy cost. C2.6 Designing more optimum building's cover to reduce embodied energy. C2.7 Designing the buildings with an innovative structure to reduce embodied energy.		GBC Indonesia, 2013; Birgisdottir et.al, 2017; Orr at.al, 2017; Pöyry et.al, 2015; Yu et.al, 2016; Holtzhausen, 2007; Malmqvist et. al, 2018; Balouktsi & Lutzkendorf, 2016; Fuertes, 2017; Krantz et.al, 2015; Uda et. al, 2020.

Table continued

2	Design Phase	The Design of Building Flexibility and Efficiency (B4)	<p>D2.1 Designing low maintenance buildings (replacement, repair, maintenance, and refurbishment).</p> <p>D2.2 Designing more flexible and adaptable buildings.</p> <p>D2.3 Designing the building that pays attention to the ease of the demolition process.</p> <p>D2.4 Designing the buildings that could facilitate the materials' choices.</p> <p>D2.5 Designing easy and efficient fabrication buildings.</p> <p>D2.6 Designing the buildings based on the weather, so the materials were chosen in accordance with those conditions.</p> <p>D2.7 Designing the shape of the buildings that could be configured during the age of the buildings.</p> <p>D2.8 Designing the low maintenance buildings.</p>	EBC Annex 57, 2016; Fuertes, 2017; Dixit et.al, 2013; Usep et.al, 2014; Holtzhausen, 2007; Malmqvist et. al, 2018. Crowther, 1999; Gavotsis, E., & Moncaster, A., 2014; Uda et. al, 2020.
3	Construction Phase	The Materials of Supply Chain (C1)	<p>A3.1 Designing the optimum supply chain for materials to be used.</p> <p>A3.2 Choosing the materials' suppliers and distributors that environmentally friendly.</p> <p>A3.3 Choosing the materials' suppliers and distributors near the site to reduce transportation.</p> <p>A3.4 Choosing the experienced suppliers related to products' packaging and fragile materials' distribution to minimize the repeated delivery.</p>	EBC Annex 57, 2016; Dixit et.al, 2012; Gavotsis, E., & Moncaster, A., 2014; Uda et. al, 2020; Efstatiou & Alice, 2014; Malmqvist et. al, 2018; Dixit et.al, 2013.
		The Management of Transportation System (C2)	<p>B3.1 Managing the transportation system for project management activities (supported transportation), such as transportation for the workers, health services, etc.</p> <p>B3.2 Designing the transportation system for far project sites to reduce the embodied energy.</p> <p>B3.3 Designing the transportation system during the construction process in an effective and efficient project's environment.</p> <p>B3.4 Utilizing environmentally friendly and energy-saving means of transportation.</p>	Holtzhausen, 2007; Crowther, 1999; Malmqvist et. al, 2018; Uda et. al, 2020; Gavotsis, E., & Moncaster, A., 2014; Dixit et.al, 2013.
		The Method of Construction (C3)	<p>C3.1 Designing and developing the process of energy-saving technology on the steps of construction, utilization and maintenance of the buildings.</p> <p>C3.2 The effective method of construction to prevent the dissipation of materials, time, tools and workers.</p> <p>C3.3 Utilizing the old building's structure that could be functioned without losing its function and strength.</p> <p>C3.4 Utilizing the BIM method on the more effective and efficient construction process.</p> <p>C3.5 Utilizing the light-weight construction.</p>	EBC Annex 57, 2016; Birgisdottir et.al, 2017; Malmqvist et. al, 2018; Dixit et.al, 2013; Gavotsis, E., & Moncaster, A., 2014; Krantz et.al, 2015; Uda et. al, 2020; Goggins, J., 2012.
		The Efficiency and Optimization of heavy vehicles (C4)	<p>D3.1 Designing the choices of heavy vehicles in accordance with the construction's needs.</p> <p>D3.2 Optimizing the utilization of heavy vehicles during the construction process.</p> <p>D3.3 Utilizing the energy-saving and low carbon heavy vehicles.</p> <p>D3.4 Placing the skillful and experienced operators of heavy vehicles.</p> <p>D3.5 Decreasing the dissipation of heavy vehicles' utilization.</p>	EBC Annex 57, 2016; Gavotsis, E., & Moncaster, A., 2014; Dixit et.al, 2013; Krantz et.al, 2015; Monteiro S.C.A., 2015; Uda et. al, 2020.
		The Utilization of the Materials to the supporting buildings (C5)	<p>E3.1 Utilizing the environmentally friendly and low embodied energy materials for the supporting buildings, such as the project's office, the workers' mess, and materials' warehouse.</p> <p>E3.2 Utilizing the reused materials and recycled materials as a fence protector and scaffolding.</p> <p>E3.3 Utilizing environmentally friendly and low embodied energy materials for K3 tools for workers and project sites.</p>	GBC Indonesia, 2013; Dixit et.al, 2012; Birgisdottir et.al, 2017; Poyry et.al, 2015; Uda et. al, 2020; Hammond et.al, 2008; Malmqvist et. al, 2018.
		The efficiency of electrical energy and energy alternative utilization (C6)	<p>F3.1 Optimizing the utilization of electricity during the project.</p> <p>F3.2 Utilizing environmentally friendly alternative electricity, such as solar system.</p> <p>F3.3 Decreasing the utilization of diesel energy as the main electricity source.</p> <p>F3.4 Utilizing the energy-saving lightings as the project's lighting fixtures.</p>	Chastas et al., 2016; Feng et al., 2016; Giordano et al., 2015; Goggins, J., 2012; Sattary, A & Thorpe, D., 2012.

Table continued

3	Construction Phase	Repeated works (C7)	G3.1 Managing the workers to reduce the repeated works and dissipation of materials and energy. G3.2 Decreasing the mistakes of giving instructions and pieces of information in each process of construction. G3.3 Designing and scheduling the materials and tools' needs to avoid cumulation and dissipation in the project's site. G3.4 Minimizing the mistakes to order the materials and heavy vehicles.	EBC Annex 57, 2016; Dixit et.al, 2013; Balouktsi & Lutzkendorf, 2016; Rasmussen et.al, 2018.
		The skill of the workers (C8)	H3.1 Educating the workers to increase their skill and ability towards energy and material efficiency. H3.2 Applying the quality management system to the workers in each work. H3.3 Certificating the skills of each worker. H3.4 Tight supervising in the construction process.	Balouktsi & Lutzkendorf, 2016; EBC Annex 57, 2016; Rasmussen et.al, 2018; Dixit et.al, 2013.
		The Management of used materials/ waste (C9)	I3.1 Choosing the shortest transportation way to transport the used materials/ waste to the dump area. I3.2 Processing the wasted/ used materials during the construction activities. I3.3 Minimizing the landfill at the end of the project. I3.4 Utilizing the used land garden work others.	EBC Annex 57, 2016; Birgisdottiret.al, 2017; Gavotsis et. al, 2014; Dixit et.al, 2013; Malmqvist et. al, 2018; Ramesh et.al. 2010
		Reuse & Recycle materials (C10)	J3.1 Method of wasted/ used materials' cleaning by reuse and recycled. J3.2 Utilizing the used materials for the next projects. J3.3 Using the recycle technology to reuse the materials.	GBC Indonesia, 2013; EBC Annex 57, 2016; Crowther, 1999; Uda et. al, 2020.
4	Operation /Maintenance Phase	The Operational building (D1)	A4.1 Utilizing the alternative environmentally friendly electricity. A4.2 Utilizing energy-saving lighting fixtures by the sensory system. A4.3 Utilizing the energy sensory system for elevator and lift while unoperated. A4.4 Utilizing the low voltage and energysaving air conditioning (HVAC). A4.5 Optimizing the energy utilization to the electrical equipment. A4.6 Utilizing the low voltage and energy-saving water heater. A4.7 Utilizing the energy-saving pumping water machine on the sanitation system.	GBC Indonesia, 2013; EBC Annex 57, Macias et al, 2017; Waldron et al, 2013; Uda et. al, 2020; Giordano et al., 2015; Giordano et al, 2017.
		Maintenance, Repair, Replacement & Refurbishment (D2)	B4.1 Utilizing environmentally friendly and low energy materials for renovation. B4.2 Choosing the shortest transportation for material supply. B4.3 Utilizing the energysaving equipment during the maintenance and renovation.	Macias et al, 2017; Waldron et al, 2013; Giordano et al., 2015; Giordano et al, 2017; Uda et. al, 2020.

---

## REFERENCES

- [1] United Nations Environment Programme (UNEP), 2015, Resources efficiency in Buildings, the International Energy Agency (IEA) for the Global Alliance for Buildings and Construction (GlobalABC), Online available from <http://www.unep.org>
- [2] A. Sattary & D. Thorpe, Optimizing embodied energy of building construction through bioclimatic principles. In: Smith, S.D (Ed) Proc 28th Annual Association of Researchers in Construction Management, p.1401-1411, 2012.
- [3] C.J Cleveland & Morris C, *The Dictionary of Energy, Expanded Edition*, The Encyclopedia of Energy, Elsevier Science, 2009.
- [4] D.D Tingley & B. Davinson, Design for deconstruction and material reuse, Proceedings of the Institution of Civil Engineers – Energy, November 2011, Vol. 164, no. 4, p. 195-204, 2011.
- [5] B. Edwards, Sustainable Architecture, Second Edition: European Directives and Building Design 2nd Edition, Oxford, Architectural Press(Butterworth-Heinemann), 1999.
- [6] P. Crowther, Design for disassembly to recover embodied energy, in: The 16th Annual Conference on Passive and Low Energy Architecture 2017, p. 95-100, 1999.
- [7] G.D. Oberlender, Project Management For Engineering And Construction Third Edition, McGraw-Hill Education, USA, 2014.
- [8] H.L.Guo, H. Lie, M. Skitmore, Life-Cycle Management of Construction Projects Based on Virtual Prototyping Technology, Journal of Management in Engineering, Vol.26, no.1, pp. 41-47, 2010.
- [9] M.K. Dixit, J.L. Fernández-Solís, S. Lavi, C.H. Culp, Identification of parameters for embodied energy measurement: A literature review, Energy and Buildings, Vol. 42, no.8, p 1238–1247, 2010.
- [10] M.K. Dixit, J.L. Fernández-Solís, S. Lavi, C.H. Culp, Need for an embodied energy measurement protocol for buildings: A review paper, Renewable and Sustainable Energy Reviews, Vol. 16, no.6, p.3730– 3743, 2012.
- [11] M.Balouktsi & T. Lutzendorf, Energy Efficiency of Building: The Aspect of Embodied Energy, Energy Technology , vol.4, no.1, p 31 – 43, 2016.
- [12] A.B. Larriba, & O. Wolf, Analysis and evaluation of 3 rd draft criteria for Buildings and next steps, Institute for Prospective Technological Studies, JRC Europe Commission, 2010.
- [13] G.D. Garson, Partial Least Squares: Regression and Structural Equation Models, Statistical Associates Blue Book Series Partial Least Squares (PLS-SEM) 2016 edition, copyrighted by G. David Garson and Statistical Associates Publishing, USA, 2016.
- [14] B. Efron, D. Rogosa and R. Tibshirani, Resampling methods of estimation. In N.J. Smelser, & P.B. Baltes (Eds.). International Encyclopedia of the Social & Behavioral Sciences (pp. 13216-13220). New York, NY: Elsevier, 2004.
- [15] T. Ramesh, R. Prakash, K. Shukla, Life cycle energy analysis of buildings: an overview, Energy and Building, Vol. 42, no.10, p 1592–1600, 2010.
- [16] R. Giordano, V. Serra, E. Demaria, A. Duzel, Embodied energy versus Operational energy in a nearly zero energy building case study, 8th International Conference on Sustainability in Energy and Building 2017, Energy Procedia, Vol. 111, p 367 – 376, 2017.
- [17] T. Malmqvist, M. Nehasilova, A. Moncaster, H. Birgisdottir, N.F. Rasmussen, A. H. Wilberg, J. Potting, Design and Construction strategies for reducing embodied impacts for building – case study analysis, Energy and Buildings, Vol.166, no.1, p35-47, 2018.
- [18] H.J. Holtzhausen, Embodied Energy and Its Impact on Architectural Decisions, Sustainable Development and Planning III, WIT Transactions on Ecology and the Environment, Vol 102, no.9, p 377-385, 2007.
- [19] M. Yu, T. Wiedmann, R. Crawford, C.Tait, The carbon footprint of Australia’s construction sector, International High- Performance Built Environment Conference – A Sustainable Built Environment Conference 2016 Series (SBE16), iHBE 2016, Procedia Engineering, vol.180, p.211 – 220, 2017.
- [20] P. Fuertes, Embodied Energy Policies to Reduce Existing Buildings, International Conference-Alternative and Renewable Energy Quest 2017, Energy Procedia, Vol. 115, p.431 – 439, 2017.
- [21] M.K. Dixit, Embodied energy analysis of building materials: An improved IO-based hybrid method using sectoral disaggregation, Energy, Vol 124, p.46–58, 2017.
- [22] G. P. Hammond & C. I. Jones, Embodied Energy and Carbon in Construction Materials, Proceedings of the Institution of Civil Engineers Energy, vol. 161, no.2, p. 87–98, 2008.
- [23] S. Kotaji, A. Schuurmans, S. Edwards & SETAC-Europe, Life-cycle assessment in building and construction: A state-of-the-art report, Pensacola, FL: Society of Environmental Toxicology and Chemistry, 2003.
- [24] S.A.K.A. Uda, M.A. Wibowo, J.U.D. Hatmoko, Optimization of Embodied Energy in Bridge Construction, Civil Engineering and Architecture, Vol. 8, No. 6, pp. 1167 - 1177, 2020. DOI: 10.13189/cea.2020.080602
- [25] S.O. Ajayi, L.O. Oyedele & O.M. Ilori, Changing significance of embodied energy: A comparative study of material specifications and building energy sources. Journal of Building Engineering, vol 23,324-333,2019.
- [26] R. Azari & N. Abbasabadi, Embodied energy of buildings: A review of data, methods, challenges, and research trends. Energy and Buildings, Vol.168, no 1,225-235, 2018.
- [27] U. Emmanuel, C. B. Chukwuemeka, K. C. Kalu, Life Cycle Energy Assessment (LCEA) Approach: A Prospect for Sustainable Architecture in Developing Countries, Civil Engineering and Architecture, Vol. 8, No. 5, pp. 777 - 791, 2020. DOI: 10.13189/cea.2020.080505