

Evaluation of the Effects of Orientation and Coverage Areas of FRP Lamination Bonded with Two-Way RC Slabs – A Modular Approach

Balamurugan G.¹, Viswanathan T. S.^{2,*}

¹Department of Civil Engineering, Madanapalle Institute of Technology and Science, India

²Department of Structural and Geo-Technical Engineering, School of Civil Engineering, Vellore Institute of Technology (VIT), India

*Corresponding Author: viswanathan.ts@vit.ac.in

Received June 3, 2020; Revised July 29, 2020; Accepted August 10, 2020

Copyright©2020 by authors, all rights reserved. Authors agree that this article remains permanently open access under the terms of the Creative Commons Attribution License 4.0 International License

Abstract Many researchers have proposed different schemes of fiber reinforced polymer (FRP) wrapping to strengthen the Reinforced Concrete (RC) slab. However, the ideal system for FRP laminations is not readily available. A modular approach for strengthening of RC slabs (especially two-way slab) needs to be developed with respect to orientations and coverage area of FRP sheets in order to figure out the effective strengthening system. This paper describes the experimental study carried out to explore the effects of fiber reinforced polymers in different orientation and coverage areas to strengthen the structural members. Three systems of laminates have been used to strengthen the RC slabs using two types of fibers, namely carbon fiber reinforced polymer (CFRP) and glass fiber reinforced polymer (GFRP) composite. The systems are classified with respect to the orientation of FRP sheets such as edge, corner and center wrapping. Each system has three proportions of FRP coverage area in the order of 25%, 35%, and 45%. A set of fifty-four slabs were fabricated and tested at the rate of three specimens for each variant. The performance of the flexural strength of two-way RC slabs with different strengthening systems has been evaluated and compared. It shows that all the systems of strengthening are effectively enhancing the flexural strength of two-way RC slabs. The extent depends on the system orientation and coverage area of the FRP sheet. The higher-order performance is noticed when the FRP lamination has higher contact with the slab area and with closer proximity to the loaded area.

Keywords RC Slab, FRP, Strengthening, Failure Mode, Orientation and Coverage Area

1. Introduction

Structures, especially RC – Reinforced Concrete structural members are always facing new challenges during their life span, in terms of loading, structural behavior and durability. The core problem is to provide sustainable durability for the structure and structural members in an effective manner, by adopting economical and reliable repair and strengthening techniques when structures suffer some distress. The readily available strengthening techniques based on lamination with fiber-reinforced polymers (FRP) are enhancing the strength of reinforced concrete slabs (Al-Bayati, et al. 2018; Al-Saadi et al. 2016; Al-Sulayvani et al. 2015; Bonacci et al. 2001; Delnavaz et al. 2015). However, the existing techniques or methods do not have specific information and guidelines with respect to the effective coverage area and orientation of FRP composites on the RC slabs, and their performance factors are not explored fully.

Many researchers have proposed different schemes of FRP wrapping to strengthen the RC slab; Hussein et al. (2010) proposed the strengthening system for RC slabs with CFRP strips. Use of FRP for strengthening results in the effective upgrade of structural capacity of slabs up to 500% for un-reinforced specimens and 200% for steel-reinforced specimens (Mosallam et al. 2003). Aljazeera et al. (2018), evaluated the flexure performance of RC slabs with composite materials, and the composites increased the ultimate load to about 1.3 to 2 times than that of un-strengthened slabs. Gherdaoui et al. (2018) used the following orientations of the CFRP laminates used to strengthen the slabs such as 0°, 45°, 0°/90° and 45°/135°. As of the available literature reviews, it is clear that the existing strengthening systems need to be developed further for RC slab with the concern on the effective orientation and sufficient coverage area of FRPs.

From the previous research, it is understood that the ideal approach of FRP laminations is not readily available, or ideal approaches are not considered in FRP bonded RC slabs like the beams strengthening systems of U, L, and bottom FRP lamination or wrapping (ACI440-R8, 2008). It is also learnt from the literature review that all strengthening systems used in previous researches have the consent only on the enhancement of performance factors instead of an effective enhancement.

A modular approach for strengthening of RC slabs (especially two-way slab) needs to be developed with respect to orientation and coverage area of FRP sheets in order to figure out the effective strengthening system.

This paper aims to study the effectiveness of orientation with a satisfactory coverage area of FRPs on two-way RC slabs and corresponding performance factors such as flexural strength and mode of failure, ductility, and stiffness. CFRP and GFRP sheets have been used as a single ply on the two-way RC slabs for this study.

Three types of orientation have been adopted in this study, namely, Corner, Edge and Centre FRP wrapping with different coverage areas that are 25%, 35%, and 45 in each orientation type. In all the three orientations and for all the coverage areas, FRP laminates have been used only as uni-directional sheet wraps. Bi-directional sheet wraps have not been considered since bi-directional wrapping is a significant factor only if FRP Strips are used. Since, in this study, FRP Sheets are used, instead of Strips, bi-directional effect is automatically accommodated.

These coverage areas were chosen to explore the enhancement rate of flexural strength of two-way RC slabs with minimum amount of FRP wrapping. The systems have been decided with the reference of ACI440-R8, 2008, Gherdaoui et al. (2018), Hussein et al. (2010), and Mosallam et al. 2003. Although considerable research has been focused on bi-directional FRP sheets or strips with regards to its suitability as a repair and strengthening material, unidirectional FRP sheets or strips have received considerably less attention. In this study, unidirectional FRP sheets were used instead of bi-directional FRP sheets.

2. Experimental Program

2.1. Test Specimen Details

A total of fifty-four slabs with a size of 350 mm by 350 mm and 75 mm depth were fabricated for the test. The slabs are reinforced with three 8 mm diameter steel rebar in both directions at a spacing of 150 mm center to center, and the reinforcement is placed with clear cover of 20 mm from the slab's tension face, as shown in Fig. 1. The average compressive strength of six batches of concrete used to fabricate the slabs is 27 MPa based on IS 516 (1959). The steel rebar average yield tensile strength was 415 MPa conforming to IS 1608 (2005).

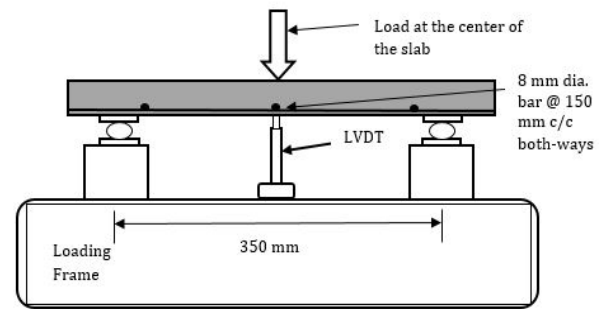

Figure 1. Test setup

2.2. Strengthening System and FRP Properties

Three FRP laminated bonded strengthening systems were used to strengthen the RC slabs with carbon fiber reinforced polymer (CFRP) and glass fiber reinforced polymer (GFRP) composite. The systems are classified with respect to the orientations of FRP sheet such as edge (θ, e_{yi}), corner (e_{xi}, e_{yi}), and center (θ, θ) wrapping. Each system has three variants of FRP coverage area which include 25%, 35%, and 45%. The Strengthening Systems are named System-I, System-II and System-III for edge, corner and center FRP wrapping, respectively. Unidirectional CFRP and GFRP sheets have been used to strengthen the RC slabs. The CFRP sheet has nominal thickness of 0.30 mm, Modulus of Elasticity 285,000 MPa, and ultimate tensile strength of 3,500 MPa. The other composite, GFRP sheet have a nominal thickness of 0.90 mm, Modulus of Elasticity 73,000 MPa, and ultimate tensile strength of 3,400 MPa. Primer and saturant were used as a bonding agent (epoxy), and it consists of base and hardener. The primer has the density of 1.14 g/cc and pot life of 25 minutes at 270° C, while the saturant has the density of 1.25 -1.26 g/cc and pot life of 120 minutes at 300° C.

3. Result and Discussion

3.1. Peak Load and Failure Pattern

The peak load and failure mode of the slabs are summarized based on the experimental result in Tables 1 and 2. Both the two FRP materials show higher-order flexural strength than the control slabs without any FRP bonding. The flexural strength factor was determined as the ratio of peak load and yielding load of specimens (Mufi et al. 1996), as shown in Table 1 (Column 8). Specimens with higher coverage area of FRP showed an increase in peak load for all three systems of orientation.

In comparison, it is found that all systems with GFRP sheets exhibited increased flexural strength effectively with higher deflection than systems with CFRP sheets. System -III specimens both with CFRP and GFRP exhibited better performance as compared to System -I

and II. In System-III, there was an increase in peak load in CFRP strengthened slabs, to the extent of 85%, 87%, and 97% with 25%, 35%, and 45% coverage area. Whereas in the system III, the slab with the GFRP sheet, the increase in peak load was to the extent of 99%, 96%, and 109% with 25%, 35% and 45% coverage area, respectively. The observation shows that the FRP wrapping is effectively

increasing the flexural strength when it is closer to the load point. It is evidenced in System- I and II slabs with 35%, and 45 % of FRP coverage area from the higher peak load values, the superior performance due to the FRP lamination has higher contact with the slab area and with closer proximity to the loaded area than 25 % coverage area.

Table 1. Yield Load and Ultimate Load from Load Test

System	Specimen identifier	$(e_{xi}, e_{yi})^a$	$(a_i)^b$	FRP Type	Load at different level (kN) ^c		Strength factor P_u/P_y	
					P_y	P_u		
–	CS	–	–	–	26.20	38.87	1.48	
I	CEC-25	0, 0.25	0.25	CFRP	32.20	46.43	1.44	
	CEC-35	0, 0.20	0.35		35.37	52.57	1.49	
	CEC-45	0, 0.164	0.45		35.13	59.23	1.69	
II	CCO-25	0.25, 0.25	0.25		37.13	54.83	1.48	
	CCO-35	0.2, 0.2	0.35		41.32	56.67	1.37	
	CCO-45	0.164, 0.164	0.45		43.15	59.28	1.37	
III	CCE-25	0, 0	0.25		52.47	71.94	1.37	
	CCE-35	0, 0	0.35		55.73	72.87	1.31	
	CCE-45	0, 0	0.45		57.82	76.72	1.33	
I	GEC-25	0, 0.25	0.25		GFRP	40.72	53.05	1.30
	GEC-35	0, 0.20	0.35			40.20	58.60	1.46
	GEC-45	0, 0.164	0.45			44.50	61.65	1.39
II	GCO-25	0.25, 0.25	0.25	45.80		58.70	1.28	
	GCO-35	0.2, 0.2	0.35	48.17		58.87	1.22	
	GCO-45	0.164, 0.164	0.45	50.43		63.05	1.25	
III	GCE-25	0, 0	0.25	55.73		77.37	1.39	
	GCE-35	0, 0	0.35	58.63		76.27	1.30	
	GCE-45	0, 0	0.45	59.09		81.55	1.38	

Note: ^a e_{xi} = ratio of distance from center of the slab to center of FRPs sheet and length of the slab along x – direction; e_{yi} = ratio of distance from center of the slab to center of FRPs sheet and breadth of the slab along y – direction; ^b a_i = percentage of coverage area of FRPs on slab; ^c P_y = yielding load of slab; P_u = Peak load.

The influence and the effects of FRP type, orientation, and coverage area are reflected through the different failure patterns of the strengthened slabs (Fig. 2-4). The details of the failure modes are presented in Table 2 (Column 6). Partial delamination or rupture or both was observed in System-I and II with both FRPs when the coverage area of FRP reaches beyond the benchmark coverage area of 25%. In System-III, with both FRPs, irrespective of coverage area, full delamination is observed initially by the yielding of steel, then crack propagation is extended towards the edge of the slab. In all the strengthened slabs, non-orthogonal flexural cracks are observed, which is different from the conventional orthogonal flexural crack of control slab.

The different trends of delamination were observed with respect to the coverage area and orientation of FRP sheet. In System-I (edge) and System-II (corner), partial delamination or rupture or no delamination was observed. The degree of delamination in System- I and II depends upon the distance between the FRP location and load point. All the 3 types of coverage area of FRP which were used in System-III (center wrapping) show the full delamination irrespective of percentage of coverage and type of FRP composite, which is due to the higher contact with the load area. It is evident that the level of delamination depends on the level of contact of FRP sheet with load point.

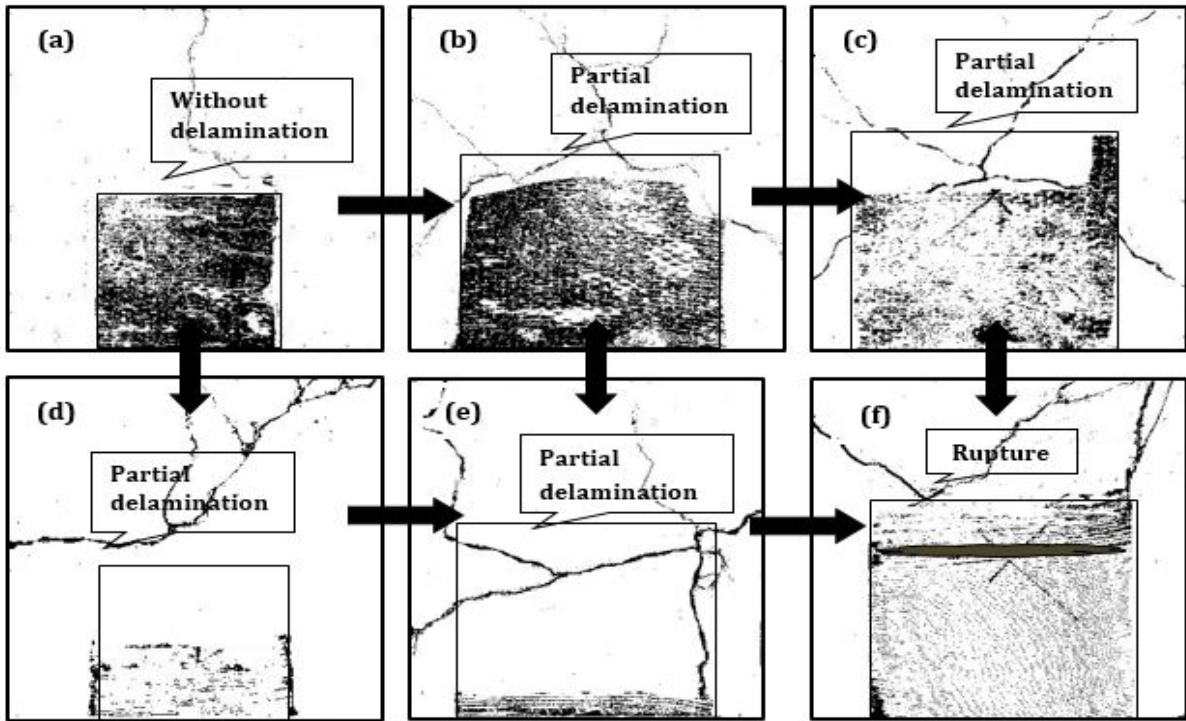

Figure 2. Failure mode for System -I specimens: (a) CEC-25; (b) CEC-35; (c) CEC-45; (d) GEC-25; (e) GEC-35; (f) GEC-45.

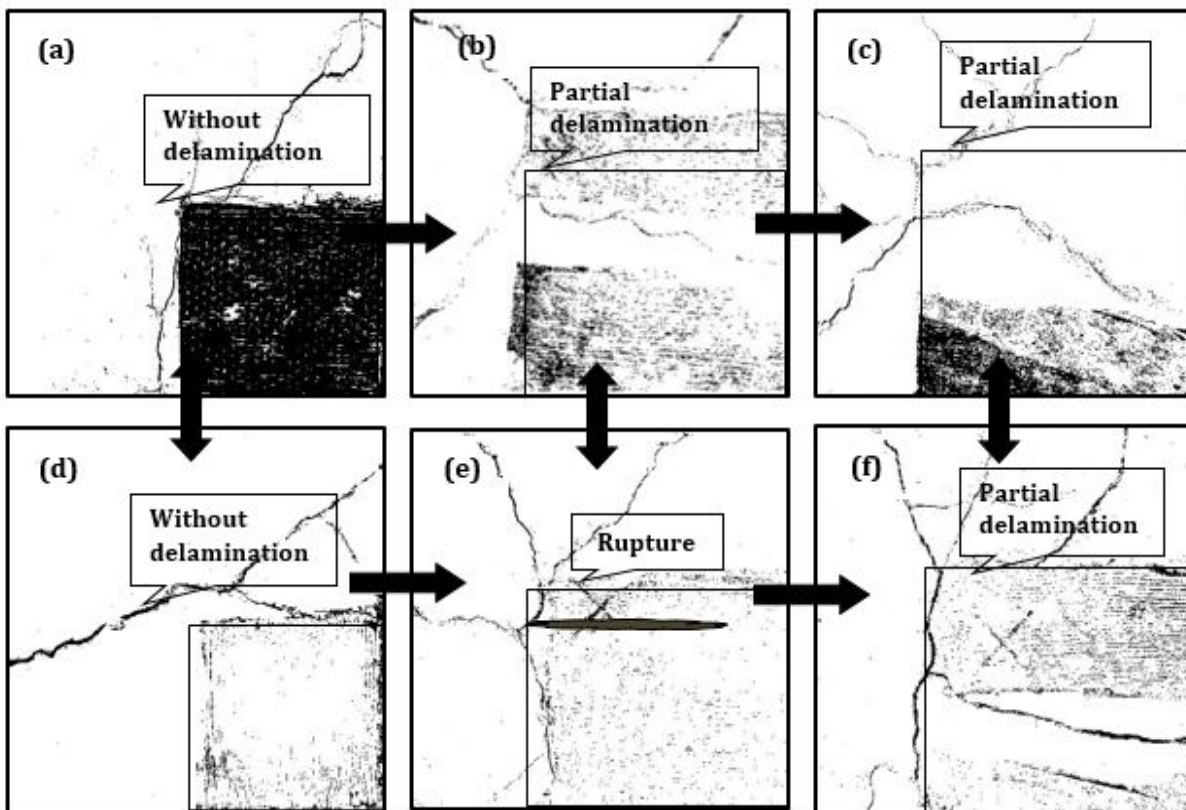

Figure 3. Failure mode for System -II specimens: (a) CCO-25; (b) CCO-35; (c) CCO-45; (d) GCO-25; (e) GCO-35; (f) GCO-45.

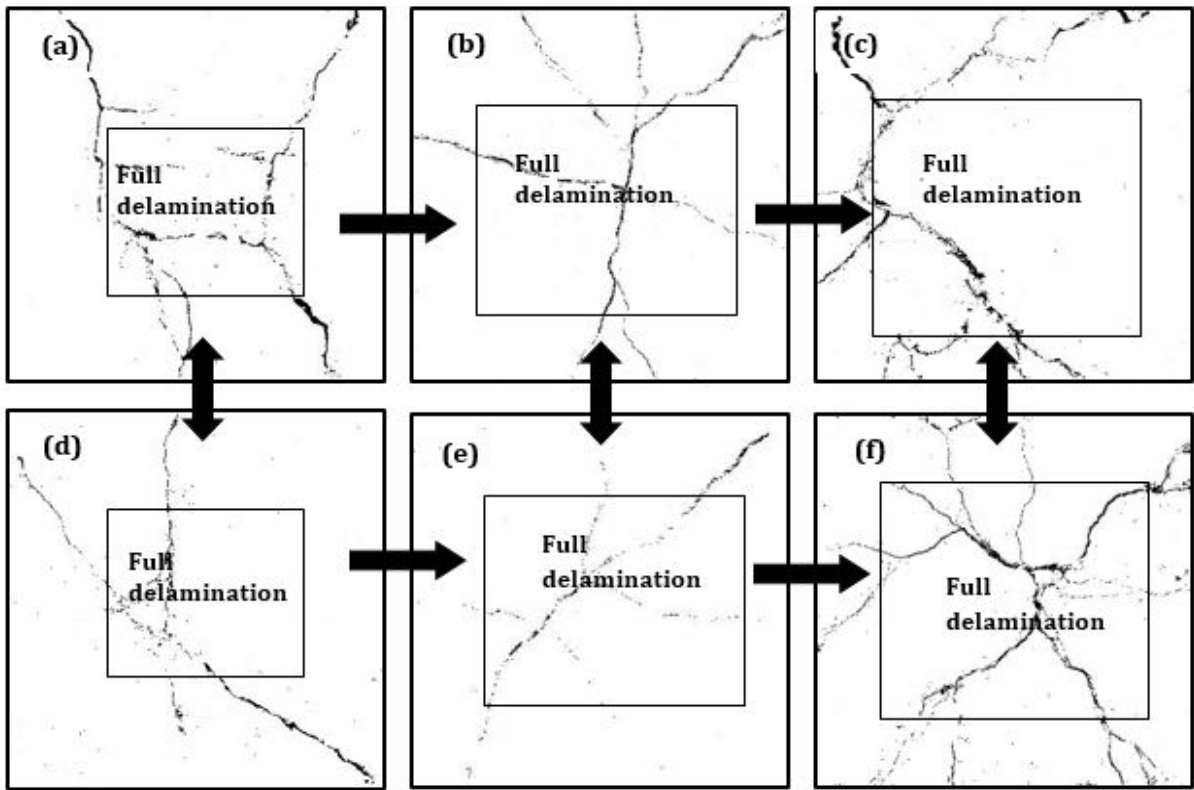

Figure 4. Failure mode for *System-III* specimens: (a) CCE-25; (b) CCE-35; (c) CCE-45; (d) GCE-25; (e) GCE-35; (f) GCE-45.

3.2. Ductility

As shown in Table 2 (Column 5), the ductility index of slabs was calculated as the ratio of ultimate displacement and yielding displacement of specimens (Aljizaeri et al. 2018; and Mufi et al. 1996). The ductility index values show that the ductility of System- I, with both FRPs up to 35 % coverage area, is more or less equal to control slab ductility. In this System - I, the reduction of ductility is noticed in 45% coverage area specimens, CEC-45, and GEC-45. In System-II, the CFRP strengthened slabs have a higher deflection ductility than the control slab. Whereas for the GFRP strengthened slabs, GCO-25 and GCO -35,

have higher ductility, but GCO-45 has its ductility reduced to about 10%. In the case of System-III, ductility increased in both FRP strengthened slabs. The maximum ductility is noticed in System-III, which is about 30% higher compared to the control slab. Observation shows, the maximum reduction in ductility of all systems is about 10 % with CFRP and GFRP sheet, which remained lesser than 30% (acceptable limit). It is confirming that the similarity in the ductility trend of Attari et al. (2012), Duic et al. (2018), and Yang et al. (20019), who used CFRP and GFRP composites for the strengthening of concrete members.

Table 2. Slab specimen test result summary: displacement at different level and pattern of failure

System	Specimen identifier	Displacement at different level (mm) ^a		Ductility index μ_y / μ_u	Pattern of Failure ^b
		μ_y	μ_u		
-	CS	3.27	5.73	1.75	YR → CP → OC
I	CEC-25	1.85	3.45	1.86	YR → CP → NOC
	CEC-35	2.74	4.82	1.76	YR → CP → PD → NOC
	CEC-45	4.44	7.05	1.59	YR → CP → PD → NOC
II	CCO-25	2.40	4.77	1.98	YR → CP → NOC
	CCO-35	2.32	4.68	2.02	YR → CP → PD → NOC
	CCO-45	2.93	6.67	2.27	YR → CP → PD → NOC
III	CCE-25	3.20	7.32	2.29	YR → CP → FD → NOC
	CCE-35	2.99	6.26	2.09	YR → CP → FD → NOC
	CCE-45	3.20	6.64	2.15	YR → CP → FD → NOC
I	GEC-25	5.20	9.87	1.90	YR → CP → PD → NOC
	GEC-35	8.60	14.83	1.72	YR → CP → PD → NOC
	GEC-45	8.92	14.06	1.58	YR → CP → R → NOC
II	GCO-25	9.09	15.78	1.74	YR → CP → NOC
	GCO-35	7.21	14.80	2.05	YR → CP → R → NOC
	GCO-45	7.39	14.59	1.97	YR → CP → PD → NOC
III	GCE-25	2.43	4.34	1.78	YR → CP → FD → NOC
	GCE-35	3.36	6.44	1.91	YR → CP → FD → NOC
	GCE-45	4.03	7.58	1.88	YR → CP → FD → NOC

^a μ_y = yielding displacement; μ_u = displacement at ultimate load; ^bYR = yield of steel rebar; CP = crack propagation extended toward the edge of the slab; OC = orthogonal flexural crack; NOC = non-orthogonal flexural crack; PD = partial delamination of FRP; FD = Full delamination of FRP; R = rupture.

3.3. Load-deflection Behavior

The load-deflection curves in Fig.5- Fig.7 show the different behaviors of various systems. The behavior differences are not only because of systems FRP sheet orientation but also due to the various amounts of coverage area. All the systems provide a significant improvement in the peak load and linear and nonlinear stiffness of the slabs. The linear and nonlinear performance was affected because of FRP types, the orientation of FRP, and the coverage area of FRP. However, the differences in load-deflection behavior have not affected the load enhancement / Load Capacity Increase of the two-way RC slabs. The load-deflection curves of various systems with different coverage areas of FRPs show that the increase of the coverage area of FRPs leads to higher-order peak loads along with higher-order displacement in two-way RC slabs.

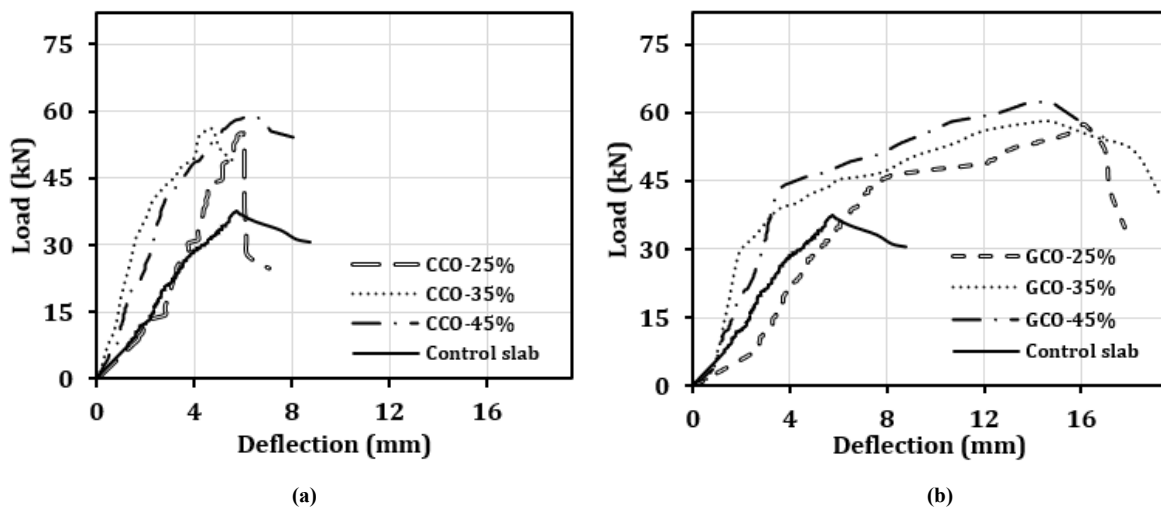

Figure 5. Load- deflection curve of System- I strengthened with: (a) CFRP sheet; (b) GFRP sheet

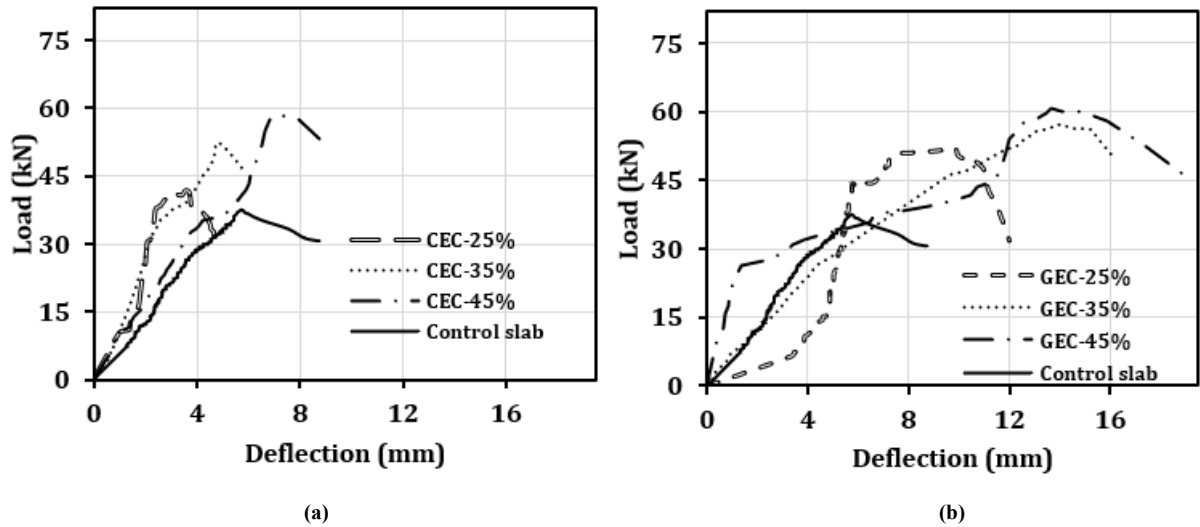

Figure 6. Load- deflection curve of *System-II* strengthened with : (a) CFRP sheet; (b) GFRP sheet

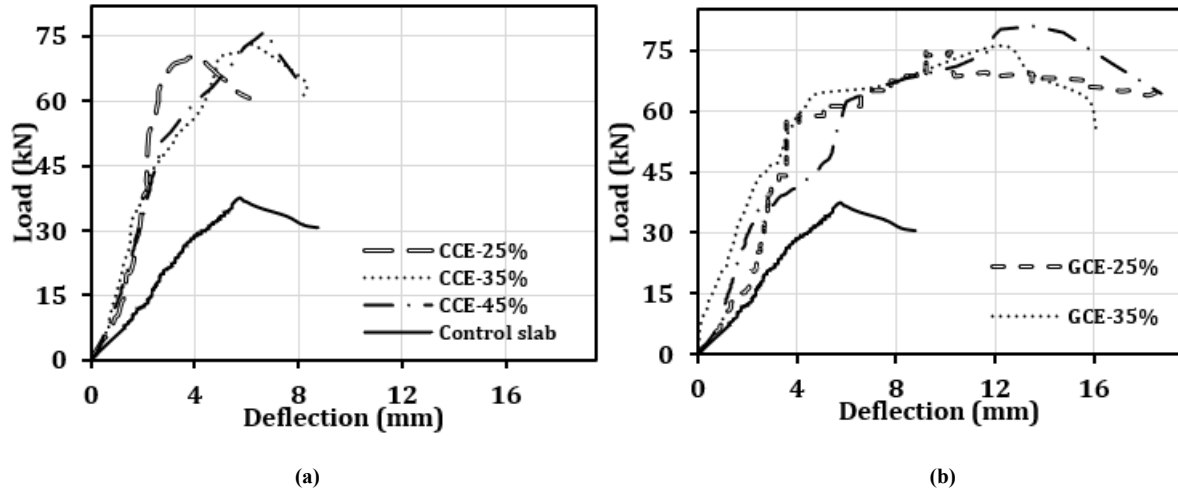

Figure 7. Load- deflection curve of *System-III* strengthened with: (a) CFRP sheet; (b) GFRP sheet

4. Conclusions

Based on the results of the experimental investigation presented in this paper, the following conclusions can be drawn.

- All the systems of strengthening enhanced the flexural strength of RC slabs. The extent of enhancement depends on the systems and their coverage area of FRP. The performance in the enhancement of flexural strength with GFRP sheet is superior to the CFRP sheet.
- The increase of ultimate load in CFRP strengthened slabs is to the extent of about 85%, 87%, and 97% with 25%, 35%, and 45% coverage area respectively. Whereas in the slabs with the GFRP sheet, the load capacity was increased by about 99%, 96%, and 109% with 25%, 35%, and 45% coverage areas, respectively.
- The maximum ductility is noticed in center wrapping, which is about 30% higher compared to the control slab.
- Both FRPs are effectively increasing the flexural strength when the wrapping is closer to the load area. It is evidenced in edge and corner wrapping with 35%, and 45 % of FRP coverage area, which shows the superior performance due to the higher contact with load point than 25 % coverage area.
- Partial delamination or rupture or both are observed in edge and corner FRP wrapping with 35% and 45% of FRP Coverage area.
- In all the strengthened slabs, a non-orthogonal flexural crack pattern is observed, which is different from the conventional orthogonal flexural crack observed in control slab.
- Further extensive research on the effect of coverage area and orientation of the FRP laminates is required

to explore the mechanism and additional factors to strengthen the RC slabs.

- A mathematical model with FEM analysis may be helpful in validating the increase in load capacity and ductility and their relationship with the percentage coverage of FRP contact area.

REFERENCES

- [1] Aljazaeri, Z. R., & Myers, J. J. (2018). Flexure Performance of RC One-Way Slabs Strengthened with Composite Materials. *Journal of Materials in Civil Engineering*, 30(7), 1–10. [https://doi.org/10.1061/\(asce\)mt.1943-5533.0002299](https://doi.org/10.1061/(asce)mt.1943-5533.0002299)
- [2] ACI (American Concrete Institute). (2008). Guide for the design and construction of externally bonded FRP systems for strengthening concrete structures. ACI 440.2R-08, Farmington Hills, MI.
- [3] Al-Bayati, G., Kalfat, R., Al-Mahaidi, R., & Hashemi, J. (2018). Experimental study on crack propagation of CFRP-strengthened RC beams subjected to torsion. *Australian Journal of Structural Engineering*, 1–19. doi:10.1080/13287982.2018.1523293
- [4] Al-Saadi, N. T. K., Al-Mahaidi, R., & Abdouka, K. (2016). Bond behaviour between NSM CFRP strips and concrete substrate using single-lap shear testing with cement-based adhesives. *Australian Journal of Structural Engineering*, 17(1), 28–38. doi:10.1080/13287982.2015.1116180
- [5] Al-Sulayvani, B. J., & Al-Talabani, D. N. (2015). Strengthening and repair of circular RC slabs with openings using CFRP strips under repeated loading. *Construction and Building Materials*, 84, 73–83. <https://doi.org/10.1016/j.conbuildmat.2015.03.058>
- [6] Attari, M A., & Raza K. (2012). Flexural strengthening of concrete beams using CFRP, GFRP and hybrid FRP sheets. *Construction and Building Materials*, 37, 746–757. <https://doi.org/10.1016/j.conbuildmat.2012.07.052>
- [7] Bonacci, J. F and Maalej M. (2001). Behavioural Trends of RC Beams Strengthened with Externally Bonded FRP. *Journal of Composites for Construction*, 5(2) 102–113. [https://doi.org/10.1061/\(ASCE\)1090-0268\(2001\)5:2\(102\)](https://doi.org/10.1061/(ASCE)1090-0268(2001)5:2(102))
- [8] Duic J., Kenno Y. S., & Das S. (2018). Flexural rehabilitation and strengthening of concrete beams with BFRP Composite. *Journal of Composites for Construction*, 22(4). [https://doi.org/10.1061/\(ASCE\)CC.1943-5614.0000851](https://doi.org/10.1061/(ASCE)CC.1943-5614.0000851)
- [9] Gherdaoui, M., Guenfoud, M., & Madi, R. (2018). Punching behavior of strengthened and repaired RC slabs with CFRP. *Construction and Building Materials*, 170, 272–278. <https://doi.org/10.1016/j.conbuildmat.2018.03.093>
- [10] Hussein, M., & Fawzy, T. M. (2010). Structural performance of CFRP-strengthened RC slabs in a corrosive environment. *Journal of Composites for Construction*, 14(6), 865–869. [https://doi.org/10.1061/\(ASCE\)CC.1943-5614.0000133](https://doi.org/10.1061/(ASCE)CC.1943-5614.0000133)
- [11] IS 269 (2015). Product manual for ordinary Portland cement [list of test equipment]. Bureau of Indian Standard, Manak Bhavan, 9 Bahadur Shah Zafar Marg, New Delhi
- [12] IS 383 (1970). Specification for coarse and fine aggregates from natural sources for concrete [CED 2: Cement and Concrete]. Bureau of Indian Standard, Manak Bhavan, 9 Bahadur Shah Zafar Marg, New Delhi.
- [13] IS 456 (2000). Plain and reinforced concrete code of practice. Bureau of Indian Standard, Manak Bhavan, 9 Bahadur Shah Zafar Marg, New Delhi.
- [14] IS 808 (1989). Dimensions for Hot Rolled Steel Beam, Column, Channel and Angle Sections. Bureau of Indian Standard, Manak Bhavan, 9 Bahadur Shah Zafar Marg, New Delhi.
- [15] IS 1608 (2005). Metallic materials – Tensile testing at ambient temperature. Bureau of Indian Standard, Manak Bhavan, 9 Bahadur Shah Zafar Marg, New Delhi.
- [16] IS 1786 (2000). High strength deformed steel bars and wires for concrete reinforcement-specification. Bureau of Indian Standard, Manak Bhavan, 9 Bahadur Shah Zafar Marg, New Delhi.
- [17] Mazloom, M., Mehrvand, M., Pourhaji, P., & Savaripour, A. (2019). Studying the effects of CFRP and GFRP sheets on the strengthening of self-compacting RC girders. *Structural Monitoring and Maintenance*, 6(1), 47–66. <https://doi.org/10.12989/smm.2019.6.1.047>
- [18] Mosallam, A. S., & Mosalam, K. M. (2003). Strengthening of two-way concrete slabs with FRP composite laminates. *Construction and Building Materials*, 17(1), 43–54. [https://doi.org/10.1016/S0950-0618\(02\)00092-2](https://doi.org/10.1016/S0950-0618(02)00092-2)
- [19] Mufti, A. A., Newhook, J. P., and Tadros, G. (1996). “Deformability versus ductility in concrete in beams with FRP reinforcement.” *Proc., 2nd Int. Conf. on Advanced Composite Materials in Bridges and Structures*, Canadian Society for Civil Engineering, Montreal, 189–199.
- [20] Yang, D. S., Park, SK., & Neale, W. K. (2009). Flexural behaviour of reinforced concrete beams strengthened with prestressed carbon composites. *Composite Structures*, 17(1), 43–54. <https://doi.org/10.1016/j.compstruct.2008.05.016>